

**Paragon  
S, SnF & TnF Series  
Instruction and Service Manual**

# CONTENTS

## PRELIMINARIES

SETTING UP THE KILN . . . . .	2
THE ELECTRIC CIRCUIT . . . . .	3
Kiln Electrical Specifications . . . . .	3
NEMA Configurations . . . . .	3
Trouble-Shooting . . . . .	4

## OPERATION

KILN SITTER AND LIMIT TIMER (For S & SnF kilns only) . . . . .	5
How to Adjust Kiln Sitter . . . . .	5
Kiln Sitter Operation . . . . .	7
Selecting Cones for Kiln Sitter . . . . .	7
Kiln Sitter Trouble-Shooter . . . . .	9

PYROMETRIC CONES . . . . .	9
FIRING CONTROLS . . . . .	11
S-Series . . . . .	12
SnF-Series . . . . .	12
TnF-Series . . . . .	13
LOADING THE KILN . . . . .	16
FIRING THE KILN . . . . .	19
Your First Firing . . . . .	19
Drying Greenware . . . . .	20
Low-Fire Greenware . . . . .	20
Low-Fire Glaze . . . . .	21
Porcelain Greenware . . . . .	21
Porcelain Glaze . . . . .	22
Overglaze . . . . .	23
Stoneware Greenware/Glaze . . . . .	24
FIRING MISTAKES . . . . .	24

## MAINTENANCE

ELEMENT MAINTENANCE . . . . .	26
Reseating a Bulging Element . . . . .	26
Testing an Element . . . . .	27
How to Replace an Element . . . . .	27
FIREBRICK MAINTENANCE . . . . .	29
Lid Maintenance . . . . .	29
Bottom Maintenance . . . . .	31
Sidewall Maintenance . . . . .	32
S & SnF SERIES SWITCH REPLACEMENT . . . . .	33
TnF-SERIES ELECTRICAL MAINTENANCE . . . . .	33
TnF-Series Diagnostics . . . . .	33
Replacing TnF Components . . . . .	36
GLOSSARY . . . . .	37
WARRANTY . . . . .	38

## READ THIS FIRST!

**Kiln owners have overfired and ruined their kilns because they didn't read this manual.** Reading the manual is time gained, not lost, because it will save you time and expense later.

You have no reason to fear your kiln—there is nothing mysterious about it—so long as you follow the manual. Even if you have fired another kiln, please read this manual.

**BEFORE YOU PLUG IN YOUR KILN**, read pages 1 through 27. Then read them again as you set up and fire the kiln. In addition, we have produced *How to Load and Fire Your Ceramic Kiln*, a 60 minute video available for a nominal fee. See your dealer for a copy or call 972-288-7557 or 800-876-4328 to have one rushed to you.

This manual covers S, SnF, and TnF-series kilns. TnF-series owners, skip past "The Kiln Sitter" section, pages 5-8. All kiln series: under "Firing Controls," starting on page 11, read "All Models." Read the controls instructions for your kiln series; skip the other series. If you are not sure which series you have, check the electrical data plate riveted to the switch box.

Temperatures for ceramics are well above the melting point of most metals, generating tremendous stresses within the kiln. The insulating firebricks expand and contract with each firing. This is necessary for the long life of your kiln. Hairline cracks will appear in the brick while the kiln is cold. Do not be concerned with these; they close tightly when the heated brick expands.

Even though your Paragon kiln has an automatic shut-off, check the kiln yourself at the expected shut-off time. The Dawson Kiln Sitter® and TouchnFire controller are reliable but not perfect. It is possible for them to malfunction and overfire your kiln if left unattended!

If you call us about your kiln, please have the model number and part number (P/N) from the kiln's electrical data plate handy.

Thank you for purchasing a Paragon kiln. We wish you many years of relaxation and creative enjoyment with your new kiln!

## IMPORTANT

Read each page of this manual in detail before you install or operate your kiln. Warranty does not cover damage caused by failure to follow instructions.

## TOXIC GLAZES

Some glazes may be unsafe and toxic when used for surfaces that will be in contact with food or drink. When you make food or drink containers, select a glaze that has been formulated, tested and labeled as approved for surfaces that will be in contact with food or drink. Follow the glaze manufacturer's instructions exactly, without any variations.

## IMPORTANT SAFETY RULES

An electric ceramic kiln is extremely safe to operate provided you follow these safety rules:

- Unplug kiln when not in use.
- Do not touch hot sides.
- Keep unsupervised children away.
- Place kiln on stand before connecting power.
- Do not install closer than 12" from any wall or combustible surface.
- Do not open lid until kiln has cooled to room temperature and all switch(es) are off.
- Fire only in a well ventilated, covered and protected area.
- Keep cordset away from hot sides of kiln.
- **DANGEROUS VOLTAGE!** Do not touch heating elements with anything.
- Disconnect kiln before servicing.
- Do not leave kiln unattended while firing.
- Wear firing safety glasses when looking into peephole of hot kiln.
- TnF Kilns: Turn controller safety switch off when kiln fires to completion.

# SETTING UP

## Unpacking the Kiln

When you receive your kiln, check for the following:

**Visible Damage:** If the carton is damaged (crushed, holes, etc.), remove the carton and check the kiln for both interior and exterior damages. If the kiln is damaged, you have two options:

a. Refuse the shipment and have it returned to the manufacturer, or

b. Accept the shipment after having the driver note the damage on the Bill of Lading. Then call Paragon at 800-876-4328 or 972-288-7557 (open Monday to Thursday, 7 a.m. to 5:30 p.m. Central Time).

**Shortages:** Check the Bill of Lading to insure that you received the correct number of packages. Note any shortages on the Bill of Lading, and have the driver sign the copy.

**Hidden Damage:** If there were no signs of visible damage and you discover damage to your kiln after the driver has left, you must notify the shipper immediately. Then call Paragon. Save all packing materials for inspection by the freight claims adjuster.

## Setting Up The Stand

Operate your Paragon kiln *ONLY* on the stand provided or on the optional deluxe stand with casters.

1 Place two stand side pieces in front of you as in the illustration. The side piece to your right goes on top of the other. Place the stand leg inside the side frame. (The screw holes will line up only if you follow this assembly sequence.) Insert bolts, tighten nuts.

2 Assemble the other corners the same way.

3 Insert the mar-proof plastic tips on the stand legs.

4 Position the stand on a concrete floor or a high temperature protective sheet. The stand must be level to alleviate stress on the kiln during firing and to prevent glazed pieces from falling off the stilts.

5 To level, place a shim UNDER the appropriate leg or legs, not between kiln's bottom and the stand.

6 Center the kiln on the stand providing for a minimum of 12" clearance between the kiln and the closest wall.

7 Make sure the kiln is sturdy on the stand. To move the kiln, lift it, don't push it. Pushing the kiln could collapse the stand.

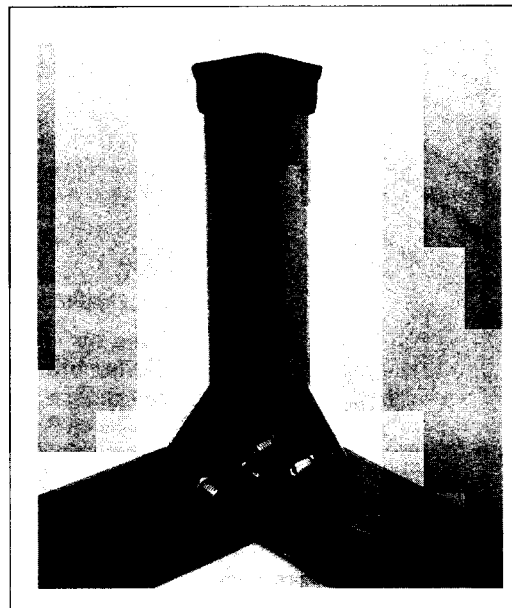

## Where to Locate Your Kiln

- Plan your firing area near a present electrical outlet or where a new circuit can easily be installed.
- Place your kiln in a well ventilated, covered and protected area such as the garage, basement, utility or ceramic hobby room. Do NOT store gasoline, paint or other flammable liquids in that room.
- Never allow the room temperature of your firing room to exceed 100 - 110°F. (Room temperature is the temperature measured three or more feet away from the kiln.) If necessary, use fans to lower room temperature.
- Provide a minimum of 12 inches clearance between kiln and the closest wall.
- Never place the kiln near curtains or other combustible materials.
- For convenience in moving the kiln out of the way when not in use, consider the reinforced, deluxe stand with casters.
- Position kiln stand on a level surface that will not be damaged by heat. We recommend a cement floor. However, a sheet of protective material may be used under the stand. Consult your hardware or building supply store for a recommendation.
- Avoid placing the kiln stand on rubber tile, linoleum or any surface that might tend to mar or discolor when heated.
- Place the kiln in an area where it can be easily loaded and unloaded yet out of the way when not in use.
- Keep unsupervised children away from the firing area.
- Do not allow kiln's power supply cord to contact the side of the kiln. This could burn the cord.
- There is little danger of serious burn from accidental contact if you exercise the same caution you would use with an electric iron.

## ELECTRIC CIRCUITS

### Seating the Elements

Shipping may dislodge the elements of your kiln. Please perform the kitchen knife test to make sure the elements are seated in their grooves.

#### KITCHEN KNIFE TEST

**CAUTION:** Always unplug kiln before touching an element with anything. (Do not plug kiln in until after you have read this manual to page 27.)

Touch only a cold element—never a hot one—with a plastic object such as a comb. Plastic will melt on and ruin a hot element.

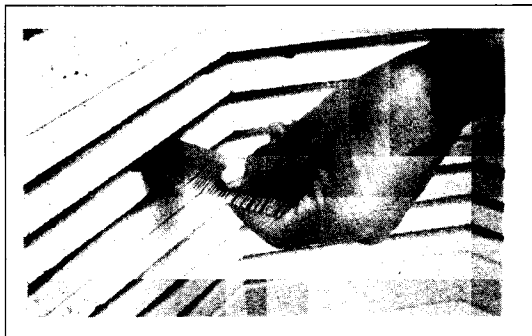

Press the elements into their grooves by running a blunt kitchen knife, plastic comb or similar blunt object completely around each groove. Do this before the first firing, because it may not be evident to the eye whether the coil is in its groove. If the element doesn't lie flat in the bottom of its groove, you needn't be concerned as long as the element fits all the way back into each corner and doesn't bulge outside the groove. In fact, elements will not lie flat in their terminal bricks (right behind switch box).

Before the kiln is fired there is no danger of breaking the elements. After firing, however, the elements must be reheated if they bulge out of the groove. See "Reseating a Bulging Element," page 26.

### Cleaning the Kiln

Clean your kiln before firing. Use a soft brush nozzle on a vacuum cleaner to remove brick dust from inside the kiln, especially from the grooves. A damp cloth or damp sponge may also be used to gently wipe dust from sidewalls and brick bottom. Clean the kiln again whenever you notice dust inside.

## ELECTRIC CIRCUITS

Your kiln must be plugged into a correctly wired circuit. If you plan to use an existing circuit, have a qualified electrician check the circuit and compare wire and breaker sizes with those on the Electrical Specifications chart on this page. The circuit must never be used by other appliances while the kiln is firing.

### Voltage Affects Firing Time

Voltage fluctuation can vary the firing time for a given pyrometric cone from as little as one half to more

than twice the average time. If the voltage is too low, the kiln will never reach full temperature. This can be corrected only by having the utility company adjust the voltage. (However, 208 volts cannot be adjusted to 240 volts, and vice versa.)

### Check the Electrical Installation

Check the receptacle voltage with a voltmeter before plugging in your kiln. Only a qualified person should perform this test, because improper use of a voltmeter can result in shock to the user. The voltage should measure within 10 volts of the kiln's rated voltage.

Verify that the neutral circuit wire is properly connected. This can be proven only by visual inspection of receptacle wiring.

### Electrical Specifications

Specifications on the kiln's electrical data plate supersede specifications on this chart.

This chart is for United States and Canadian 120 and 240 volt, single phase models with a factory-installed cordset only. For foreign countries, refer to the kiln's electrical data plate. Your electrical circuit should be installed only by a licensed electrician and in accordance with local codes.

*Changing the cord plug will void your warranty!*

### NEMA Wall Receptacle Configurations

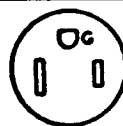

6-50R  
50 Amps.  
250 v.  
2 1/8" dia.

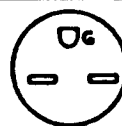

6-30R  
30 Amps.  
250 v.  
2 1/8" dia.



6-20R  
20 Amps.  
250 v.  
1 3/8" dia.



5-20R  
20 Amps.  
120 V.  
1 3/8" dia.

## Trouble-Shooting

### KILN WILL NOT FIRE

#### Probable Causes:

- *Tripped Circuit Breaker or Blown Fuse*
- *Cord Not Plugged In*
- *Kiln Sitter Plunger Not Locked Into Position (S & SnF)*
- *Limit Timer Clock Not Set (S & SnF-series)*
- *Kiln Sitter Contacts Dirty (S & SnF-series)*
- *Defective Transformer (TnF-series)*
- *Defective or Disconnected Relays*
- *Blown Kiln Switch Box Fuse (TnF-series)*

**All Models:** Check circuit breakers or fuses first. Check the wall receptacle voltage with a voltmeter. (Only a qualified person should perform this test.)

**66 & 66-3 Kilns of All Series:** Elements are wired in series; one broken element can prevent the kiln from heating. Check the elements with an ohmmeter. (See page 27.)

**S & SnF-series:** Set timer clock *before* pushing in Kiln Sitter plunger. If the wall receptacle checks out okay with a voltmeter, and the pilot light does not light, the problem may be a disconnected switch box wire or dirty Kiln Sitter contacts. UNPLUG the kiln and remove the switch box. Check for disconnected wires. Compare switch box wiring to the wiring diagram. If wiring is okay, check the Kiln Sitter contacts with an ohmmeter.

**TnF-Series:** Check the kiln switch box fuse (see page 34). If replacement kiln fuses keep blowing and you are using the correct fuse (AGC 1/2 A 250V AC), replace the kiln's transformer. (See page 37.)

### NOT ALL ELEMENTS FIRE

#### Probable Causes:

- *Broken Element*
- *Defective Switch (S & SnF-series)*
- *Disconnected Wire Inside Switch Box*
- *Defective Relay*

Check the elements with a ohmmeter (see page 27). Always UNPLUG kiln before opening switch box or touching elements. (TnF-series owners, see page 33 for more diagnostics.) Also, see "Kiln Will Not Fire" above.

### SLOW FIRING, AND/OR KILN WILL NOT REACH MAXIMUM TEMPERATURE

#### Probable Causes:

- *Low Voltage*
- *Firing Moist Greenware*
- *Worn Elements*
- *Loading the Kiln Heavier Than Usual*

Firing moist greenware can slow the firing to a crawl. It will also rust kiln parts and shorten element life. See page 20 for a discussion of moist greenware.

Keep a firing log book. If the firing time gradually increases over a long period, it is probably due to worn elements.

Before replacing elements, make sure the problem is not merely low voltage. Low voltage can double firing

time and strain elements. It is common during hot summer days. If low voltage is a problem, schedule firing during off-peak hours.

You may also be firing a 240 volt kiln on a 208 volt outlet. (240 and 208 volt receptacles look the same.) If you are not sure which voltage you have, call your power company.

### FUSE BLOWS OR CIRCUIT BREAKER TRIPS

#### Probable Causes:

- *Overloaded Circuit*
- *A Short in the Receptacle Wiring or Kiln Wiring*

If the kiln blows a fuse or trips a breaker immediately, the problem is a short in the kiln wiring or circuit wiring. Do not attempt to fire until corrected.

If the fuse blows or breaker trips after the kiln has fired for some time, the problem is an overloaded circuit, not a short circuit. (A short circuit or "short" causes a large amount of current to flow, generating so much heat that the fuse or breaker opens the circuit almost instantly.) Make sure no other appliances are used on the kiln's circuit. Have an electrician check the circuit wire and breaker sizes. If the breaker trips only once in awhile, you may have a "weak" breaker that should be replaced.

Wire heats when an electric current passes through it. If the same current passes through both a small wire and a large wire, the smaller will reach a higher temperature. A fuse uses this principle to protect the wiring in a building. It has a small, short wire of low melting temperature metal connected in such a manner that all current passing through the circuit must also pass through the fuse. A circuit breaker uses a tiny heating element to heat a thermostat, which interrupts the current when the maximum safe amount is reached.

A loose or poor connection at the fuse or breaker will generate heat. If the fuse or circuit breaker panel feels unusually warm, have your electrician check for loose connections, particularly at the center screw of the fuse socket, even in a new fuse box.

### HOT PLUG OR OUTLET

If you smell burning plastic, turn off the breaker immediately. Touch the wall receptacle faceplate. If it feels hot, replace the receptacle. Replace the kiln cord if it has been damaged by heat. Do not fire until repaired.

### MIDDLE ELEMENTS DO NOT GLOW RED

The middle elements in most Paragon kilns do not glow as bright as the top and bottom elements. Do not be concerned as long as the kiln is firing properly.

### KILN HEATS UNEVENLY

You can increase heat in a section of the kiln by loading that section lighter; lower heat by loading heavier. Increase mass to lower temperature; decrease mass to raise temperature. Fire the kiln more slowly. Slow firing gives the heat time to even out inside the firing chamber.

### KILN SHUTS OFF TOO SOON OR TOO LATE

**S & SnF series:** See "Kiln Sitter Trouble Shooter," page 9. **TnF series:** See "Fine-Tuning Cone-Fire to a Shelf Cone," page 14.

# KILN SITTER AND LIMIT TIMER

TnF-series owners, skip this section. Go directly to "Pyrometric Cones," page 9, the next section. Kiln Sitter® is a registered trademark of W. P. Dawson, Inc.

## How the Kiln Sitter Works

When correctly adjusted, the Kiln Sitter shuts off the power to your kiln when a properly inserted, small, pyrometric cone or pyrometric bar sags under the actuating rod.

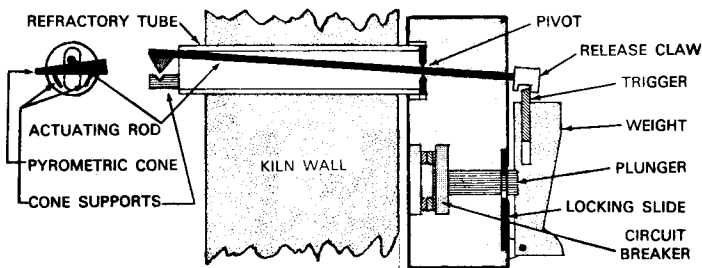

When the plunger (see photo and diagram) is pressed, a locking slide holds the plunger in position, closing the four contact points of the Kiln Sitter circuit breaker. The kiln then receives power. When the cone or bar fires to maturity and sags, the actuating rod sags with it. The release claw rises at the same time, causing the weight to fall and the locking slide to release the plunger. The contact points separate and the current is interrupted.

The Limit Timer is a clock motor that acts as a back-up electrical power shut off. Turn the dial to the number of hours you think the firing will take, and add 15 to 30 minutes. Should the Kiln Sitter weight fail to drop, the clock motor will shut off the kiln.

The Limit Timer will help you to learn to estimate firing time. For example, if the timer knob is set at 10 before firing and the white dot indicator is on 6 when firing is completed, you will know the firing took four hours. After you become familiar with firing times for your ware, you will be able to set the Limit Timer accurately to shut off 15 to 30 minutes after the expected firing time. The Limit Timer is designed to prevent an overfire should the Kiln Sitter weight fail to drop.

The Limit Timer may be set for any period up to twenty hours and may be adjusted at any time during firing.

*Never set the Limit Timer beyond 20 hours. This could result in an overfire should the Limit Timer motor stop running.*

**WARNING: Since proper operation and control of the Kiln Sitter and Limit Timer rest wholly with the operator, we cannot extend our warranty to cover any damages caused by overfiring, regardless of the circumstances.**

**DO NOT LEAVE KILN SITTER UNATTENDED. For longest life of your kiln and for safety, all kiln switches must be in OFF position before Kiln Sitter plunger is pushed in. Pushing in plunger with kiln switches on will result in extra wear on Kiln Sitter contact points.**

GUIDE PLATE  
ADJUSTING SCREWS

RELEASE CLAW

GUIDE PLATE

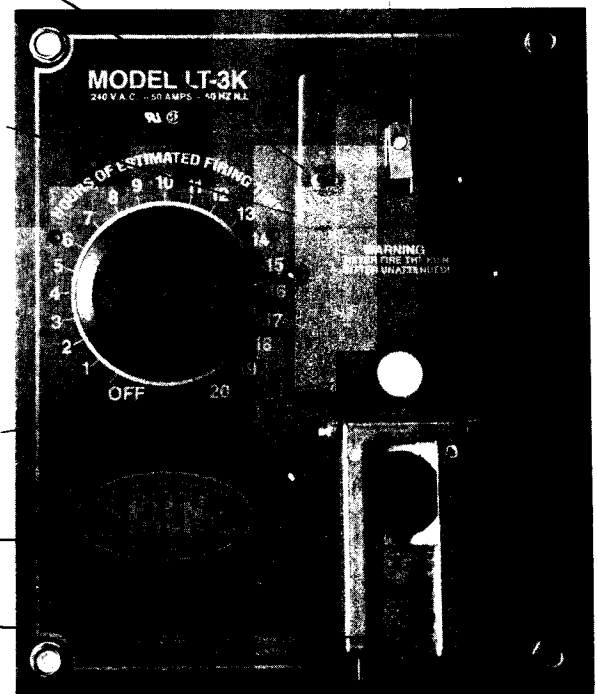

The primary value of the Kiln Sitter is the convenience of relief from closely watching the large cones through the peepholes and the uniform firing from one firing to the next. It is a mechanical device and cannot be considered fully automatic nor relieve the user from responsibility for damage due to overfiring. It must be kept in good working order and tested before EACH firing. To test Kiln Sitter, see #3 under "How to Adjust Kiln Sitter."

Your Kiln Sitter was adjusted properly when shipped from the factory, but vibration during shipping may have moved the guide plate. You MUST adjust the Kiln Sitter, as we will show you next, before you fire your kiln.

REFRACTORY TUBE

FIRING GAUGE

REMOVABLE  
CONE SUPPORTS

ACTUATING ROD

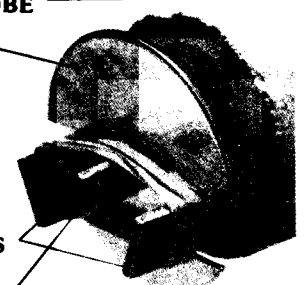

## How to Adjust Kiln Sitter

Your kiln will arrive with the firing gauge (trigger adjusting gauge) in place on the cone supports with the actuating rod inserted through the center hole. Remove the rubber band that holds the gauge in place, then



remove gauge. Save the gauge for future adjustment. *Do not fire with gauge in place!*

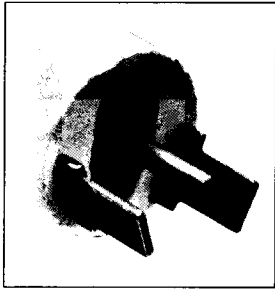

**1** Check position of actuating rod. (The actuating rod is easier to see if you hold a small mirror inside the kiln.) Rod should be centered sideways in the oblong slot in the refractory tube. If not, loosen the two guide plate adjusting screws and move the plate to the right or left, as necessary. After rod is centered, tighten guide plate screws.

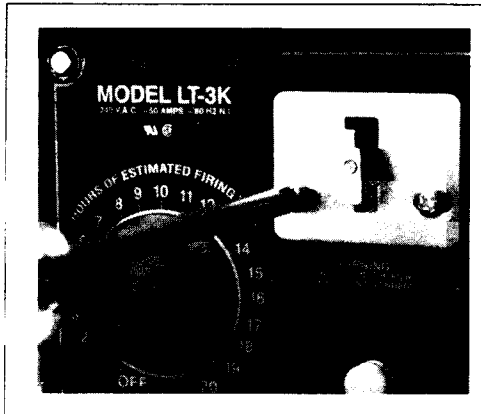

**2** Test full travel of actuating rod. Watch the actuating rod inside the kiln as you move the release claw up and down. The actuating rod should be free to move within the tube without touching the sides.

If rod does not fall freely to the bottom of tube, check the guide plate to see that its slot is parallel to the direction of travel of the release claw. If not, straighten the guide plate and readjust rod centering.

*As the Kiln Sitter develops wear, the actuating rod may no longer fall freely within the tube. This is usually caused by a corroded tube assembly. Replace tube assembly.*

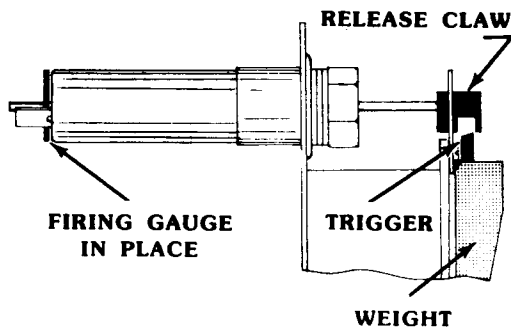

Insert end of actuating rod through hole in firing gauge (trigger adjusting gauge) on cone supports. Lift weight to the fully raised position shown in the photo. The trigger should just clear the release claw, coming as close as possible without touching. If trigger is too high to clear release claw or if it is too low, loosen the

set screw in center of weight, move trigger up or down until it just clears the release claw, and retighten set screw.

**3** Test the mechanical operation. With all kiln switches in OFF position, raise the weight and press down the release claw over the trigger. Weight **MUST NOT** be able to stand up alone and trigger **MUST** lean against release claw.

With your other hand, hold up the end of the actuating rod inside the kiln. Let go of the release claw. The release claw should hold the weight in up position while the end of the actuating rod is held up inside the kiln.

Set Limit Timer clock. Push plunger all the way in until it locks into position. (Limit Timer clock **MUST** be set before plunger will lock into position.)

Move the actuating rod slowly downward until claw releases trigger. Weight should fall all the way to the bottom, releasing the plunger and allowing it to return to its original position. Repeat the operation at least 25 times to loosen the mechanism.

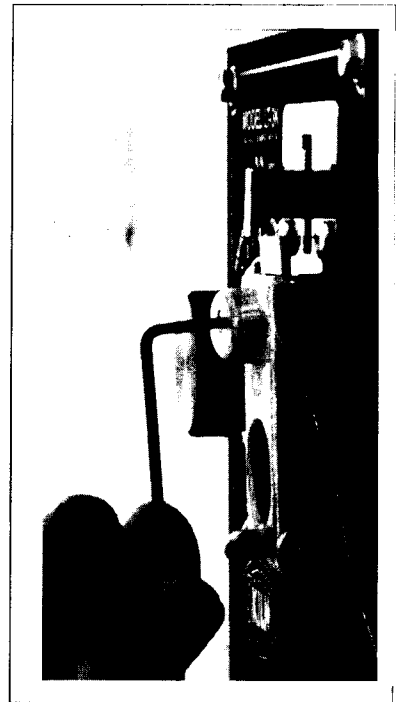

Loosen screw in weight to adjust the clearance of kiln sitter trigger.

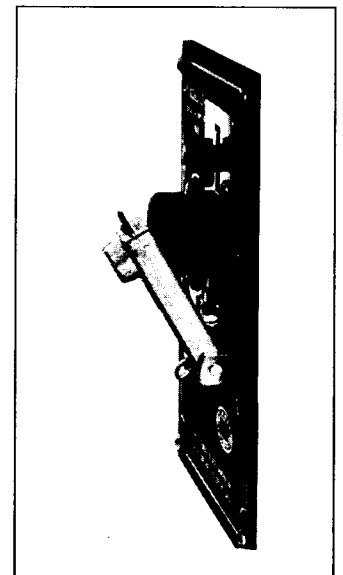
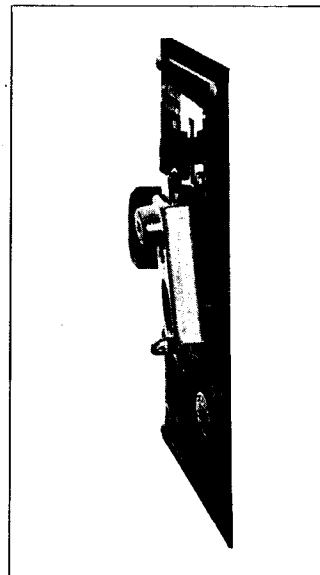

# KILN SITTER AND LIMIT TIMER

## Kiln Sitter Operation

Regardless of your firing experience, check the operation of any new Kiln Sitter by watching large pyrometric cones placed in the kiln behind a peephole for at least 12 firings. We recommend that you use large cones for each firing; their cost is less than the smallest piece of greenware, and using the large cone is the only way to check the accuracy of your Kiln Sitter.

- 1 Turn kiln switch(es) to OFF position.
- 2 Remove metal gauge and save.

**CAUTION:** Do not fire with metal gauge in place! Serious damage to kiln and Kiln Sitter will result.



- 3 Apply a thin coat of all-purpose, high fire kiln wash to the upper edges of the cone supports and the lower side of the actuating rod. The application of kiln wash should be thin enough to dry in 5 to 10 minutes.

**WARNING:** This MUST be done before each firing. Otherwise the cone could stick to the metal and prevent the Kiln Sitter from shutting off the kiln. Remove old kiln wash and apply new before each firing. Do not allow kiln wash to touch cone or inside of tube. Make sure the kiln wash has dried before inserting the cone.

- 4 Raise the weight and press the release claw down over the trigger.

- 5 Place a small pyrometric cone under the actuating rod and on top of the cone supports with your other hand. You must always have at least  $\frac{3}{16}$ " of the thick end of the cone extending past the cone support.

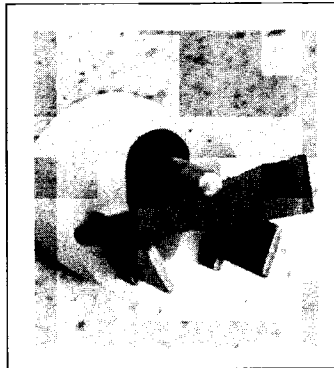

- 6 Load the kiln for firing, placing the correct pyrometric cones behind each peephole. (See "Load and Fire" section.)

Keep all ware and kiln shelves at least  $\frac{1}{2}$ " away from the sides, top and bottom of the end of the cone supports and actuating rod.

- 7 Keep area around the Kiln Sitter clear of objects that could interfere with the falling weight. The Kiln Sitter weight must fall completely to the bottom of the sitter to shut off the kiln.

- 8 Set the Limit Timer dial to the estimated firing time plus 15 to 30 minutes. (This must be done before the plunger will lock into position.) Push in the plunger.

- 9 Fire your ware watching the pyrometric cones through the peepholes. (See "Load and Fire" for instructions.)



## Selecting Cones for the Kiln Sitter

Only small Orton pyrometric cones or the Bell bar may be used in a Kiln Sitter. Either may not react to heat in exactly the same way as a pyrometric cone placed upright on the shelf. The weight of the actuating rod, the cone's horizontal position, and the way you place the cone in the Kiln Sitter may cause the small cone to bend before or after an upright cone of the same cone number on the shelf bends.

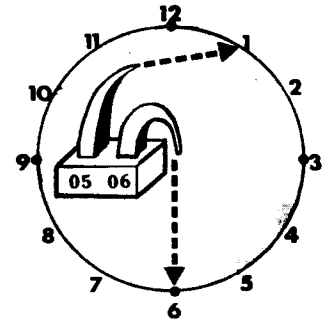
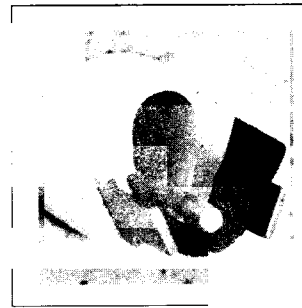

A shelf cone bends to 6 o'clock when it reaches maturity.

So for the first few firings, place three large pyrometric cones on a shelf a few inches from the Kiln Sitter cone. One of these large cones should be the same number as the small cone or bar in the Kiln Sitter. The other two large cones should be one cone hotter and one cone cooler.

For instance, if you have a small cone 05 in the Kiln Sitter, the large cones on the shelf should be 04, 05, and 06. When the Kiln Sitter shuts off and the kiln cools completely, inspect the cones. If the large cone 05 on the shelf bent to six o'clock, the small Kiln Sitter cone and the large shelf cone should be of the same cone number during future firings. If the large cone 04 bent to six o'clock, use a cone rated one cone cooler in the Kiln Sitter than on the shelf. If the large cone 06 bent to six o'clock, use a cone rated one cone hotter in the Kiln Sitter than on the shelf. (See the cone temperature chart on page 10 to understand how cones are rated.)

Since the ware is on the shelf where the large cones are placed, the large cones measure the maturity of the ware more accurately than the small cone in the Kiln



Sitter. To get like firings, you must place the cone in the Kiln Sitter exactly the same way each time you fire your kiln. You **MUST** always have at least  $\frac{3}{16}$ " of the thick end of the cone extending past the cone support to enable the Kiln Sitter to shut off before the cone melts and overfiring results. *Do not try to get a hotter firing except by the use of a hotter cone, and vice versa.*

If your Kiln Sitter has been properly adjusted with the small cone correctly inserted, the cone in the Kiln Sitter will bend into a "U" shape at the end of the firing.

## Summary of Kiln Sitter Operation

**1** Always use large cones on the kiln shelf. Make sure you can see them through the peephole and that they are no closer than 3" from the peephole.

**2** Select proper small cone for the Kiln Sitter.

**3** Make the mechanical test (see step 3 on page 6 of "How to Adjust Kiln Sitter").

**4** Clean off old kiln wash from cone supports and rod and apply new before each firing.

**5** If at any time the rod does not move freely, remove and clean the back of the guide plate and inside of the tube, then readjust.

## Loading Around Refractory Tube

Loading too close to the refractory tube could cause an overfire.

**1** Position shelves at least one inch above or below the refractory tube in case the shelf expands or tilts in tube's direction. The shelf in this picture is too close!

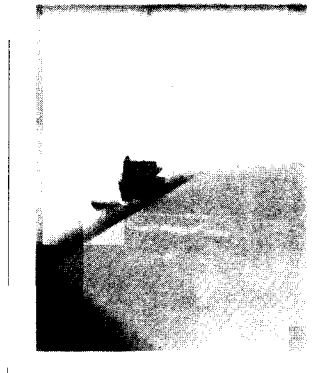

**2** Do not position poorly stilted ware near end of refractory tube, because it could fall against the actuating rod.



**3** Never load moist greenware in your kiln. It could explode and a piece could lodge beneath the actuating rod.



## POINTS TO REMEMBER

- **DO** adjust guide plate if rod does not fall freely to bottom of the oblong slot.
- **DO** leave clearance inside kiln around actuating rod.
- **DO** check kiln sitter with pyrometric cones on the shelves.
- **DO** place cone in same position in kiln sitter each time for the same firing results.
- **DO** use a hotter cone for a hotter firing.
- **DO** clean off old kiln wash from cone support holders and apply new before each firing.
- **DO** check kiln sitter adjustments often.
- **DO NOT** use your kiln before you read and understand this section.
- **DO NOT** fire with the trigger adjusting gauge in place.
- **DO NOT** throw trigger adjusting gauge away. You need it!
- **DO NOT** load shelves and ware so close to refractory tube that either would interfere with drop of actuating rod.
- **DO NOT** put anything near your kiln sitter exterior that would keep weight from dropping freely.
- **DO NOT** let kiln wash get in the refractory tube, on pyrometric cone, or on elements.
- **DO NOT** adjust trigger to control shut off point. Adjust shut off point by using cooler or hotter cones.

## PYROMETRIC CONES

### Kiln Sitter Trouble-Shooter

#### KILN SITTER SHUTS OFF BEFORE PEEPHOLE CONES BEND

- 1 Raise the weight.
- 2 Press in the plunger.
- 3 Gently lower the weight.

**WARNING:** This puts the kiln on **MANUAL CONTROL** and prevents the Kiln Sitter from cutting off automatically. When large peephole cones bend, turn the kiln switch(es) to **OFF** position. Then trip the Kiln Sitter by raising the weight and dropping.

- 4 Before the next firing, use the firing gauge to check the adjustment of the Kiln Sitter trigger (#2, page 6).

- 5 See "Selecting Cones for the Kiln Sitter," page 7.

#### PEEPHOLE CONES BEND BEFORE KILN SITTER SHUTS OFF

- 1 Turn the kiln switch(es) to **OFF** position.
- 2 After the kiln has cooled, compare the small cone in the Kiln Sitter with the large cones on the shelves.
- 3 Looking at the cone in the Kiln Sitter, determine if it has bent almost to the cut off point. In most cases, firing a few minutes longer with the Kiln Sitter cutting itself off would have no adverse effect on the ware. However, avoid overfiring glass, reds and porcelain.
- 4 See "Selecting Cones for the Kiln Sitter," page 7.

#### KILN-SITTER PARTS IDENTIFICATION

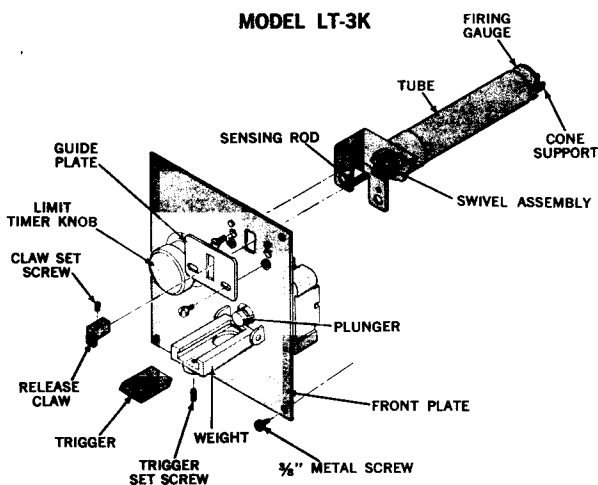
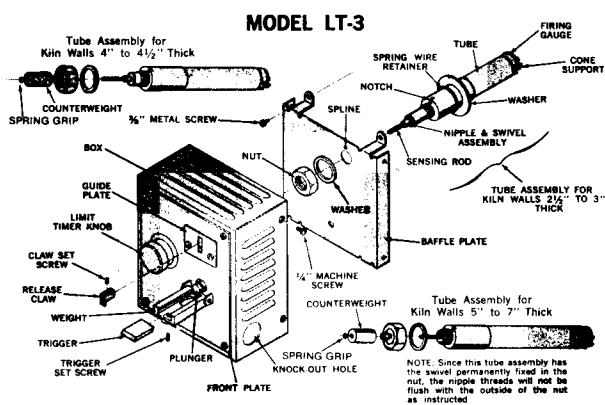

## PYROMETRIC CONES

Pyrometric cones are small pyramids of clay and mineral oxide that soften and bend when exposed to heat. They indicate when your ware has fired to maturity.

Handle cones carefully. If dropped, they may develop cracks that could affect their performance. Pyrometric cones come in two lengths: 1 1/8" and 2 1/2". The small cone is used in the Kiln Sitter and the large cone is used on the kiln shelf.

Cones mounted on the shelf must be slanted 8° from vertical. They will not bend accurately if they are slanted to the wrong angle. Large cones come in either standard or self-supporting. Standard large cones must be mounted in a clay or wire plaque with 2" of the cone exposed above the cone holder. Self-supporting cones stand upright without holders. We recommend self-supporting cones; they are easier to use and more accurate than standard large cones.

Your ware is affected by "heat work," which is the combined effect of time, temperature, and the atmosphere inside the kiln. All these factors affect the maturity of your ware and not just temperature. For instance, firing to a lower temperature for a longer time will produce the same firing maturity as firing to a higher temperature for a shorter time. The "Temperature Equivalents" chart (next page) shows that a self-supporting 05 cone requires a temperature of 1911° F. to bend to 6 o'clock, yet when fired slower, it will bend at 1870° F.

Large and small pyrometric cones are numbered from 022 through 01 and 1 through 10. Cone 022 matures at the lowest temperature, and 10 matures at the highest. The number is stamped on the side or base of the cone. The cone to use with each material is usually stated on the label by the clay or glaze manufacturer. Your supplier can also give you this information.

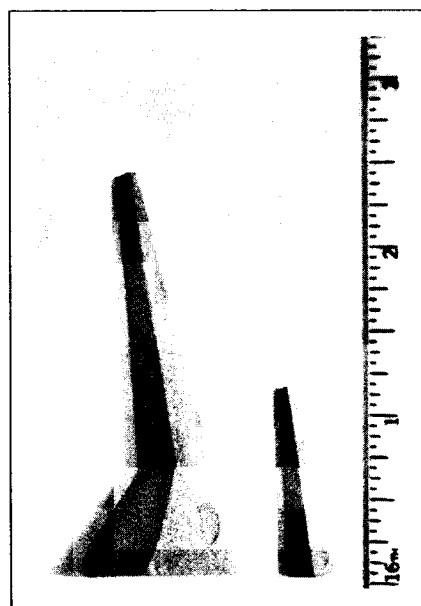

Check the accuracy of your Kiln Sitter or TnF controller by placing cones on the shelf. Mount behind each peephole a large cone of the same number you are firing to. This is the firing cone. Next to the firing cone place a large cone of a lower temperature; this is the guard cone. For example, if you are firing to cone 05, place large cones 05 and 06 on the shelf behind the peepholes. We recommend at least one large shelf cone in every firing. Kiln-wash shelves before placing cones on them.

**TEMPERATURE EQUIVALENTS °F  
ORTON PYROMETRIC CONES**

Cone Number Heated at.	Self-Supporting Cones			Small Cones 540° F. Per Hr.*
	27° F. Per Hour*	108° F. Per Hour*	270° F. Per Hour*	
022	--	1087	1094	1166
021	--	1112	1143	1189
020	--	1159	1180	1231
019	1213	1252	1283	1333
018	1267	1319	1353	1386
017	1301	1360	1405	1443
016	1368	1422	1465	1517
015	1382	1456	1504	1549
014	1395	1485	1540	1598
013	1485	1539	1582	1616
012	1549	1582	1620	1652
011	1575	1607	1641	1679
010	1636	1657	1679	1686
09	1665	1688	1706	1751
08	1692	1728	1753	1801
07	1764	1789	1809	1846
06	1798	1828	1855	1873
05 1/2	1839	1859	1877	1909
05	1870	1888	1911	1944
04	1915	1945	1971	2008
03	1960	1987	2019	2068
02	1972	2016	2052	2098
01	1999	2046	2080	2152
1	2028	2079	2109	2163
2	2034	2088	2127	2174
3	2039	2106	2138	2185
4	2086	2124	2161	2208
5	2118	2167	2205	2230
5 1/2	2133	2197	2237	N/A
6	2165	2232	2269	2291
7	2194	2262	2295	2307
8	2212	2280	2320	2372
9	2235	2300	2336	2403
10	2284	2345	2381	2426

\*Rate of temperature increase during last 90 - 120 minutes of firing.

Tables by courtesy of  
The Edward Orton, Jr. Ceramic Foundation

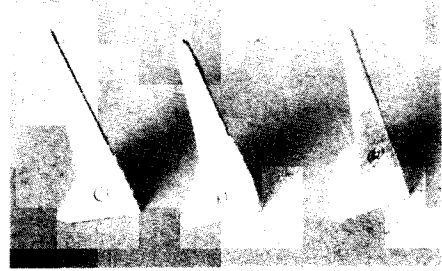

The self-supporting cones shown above have the correct slant built into the base.

Place your large cones at least 3 inches behind the peepholes to protect the cones from exposure to cool air drafts. Place the cone in a position where you have a clear path of vision to the element on the opposite side.

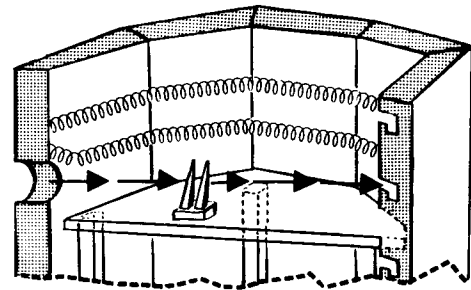

At higher temperatures, a cone is difficult to see if a piece of ware is behind it.

Always use Paragon firing safety glasses when looking into the peepholes. These glasses are specially coated to filter out the infra-red and ultra-violet light inside a kiln. They also protect your eyes from heat and reduce glare making the pyrometric cone easier to see.

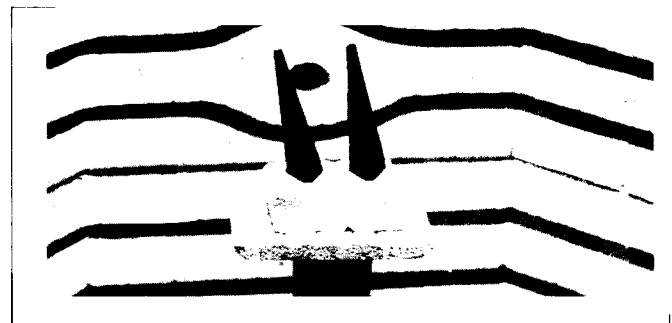

If a shelf is not level with a peephole, raise the cones with a post.

Place your cones on a shelf behind the peephole. If the size of your ware doesn't permit placing a shelf in the kiln at peephole level, use a post to raise the cones.

**Using Cones in TnF-series Kilns**

Although the DTC 800 series controllers need no shelf cones, we recommend them anyway. Place at least one self-supporting cone on a shelf behind a peephole in every firing.

## FIRING CONTROLS

If the bending of the shelf cones varies slightly from firing to firing, you need not be concerned. Since cones are manufactured from mined materials and pressed in a wet state, there are a number of variables in their manufacture that will cause cones to vary slightly from box to box or within a box. This normal variation will have no effect on your ware.

If your TnF-series kiln shuts off before the large cone on the shelf bends and you're there when it shuts off, turn the kiln back on. Instructions appear in the "Firing Controls" section. Then continue to watch the cone until it bends to six o'clock.

# FIRING CONTROLS

## All Models

The warranty on your kiln does not cover damage from overfiring, regardless of the circumstances. It is the operator's responsibility to make sure the kiln turns off when the firing is completed. *Never leave your kiln unattended near the end of the firing.*

Check your new kiln frequently during the first few firings, and note the color change inside the kiln. After awhile you can learn to estimate, with considerable accuracy, when the kiln is about to shut off, just by observing the color inside the kiln.

## THE INNER WORKINGS OF AN SnF KILN

This illustrates the firing stages of SnF-series kilns. The SnF-82 and SnF-82-3 two-switch kilns fire the same as below except that they do not have a third firing stage.

The SnF-66 and SnF-66-3 fire in two stages like the SnF-82 and SnF-82-3, but all of their elements are con-

nected to both switches. During Stage One, all the SnF-66 and SnF-66-3 elements fire at the heat setting on the top switch. During Stage Two, all the elements turn on full power.

### STAGE ONE

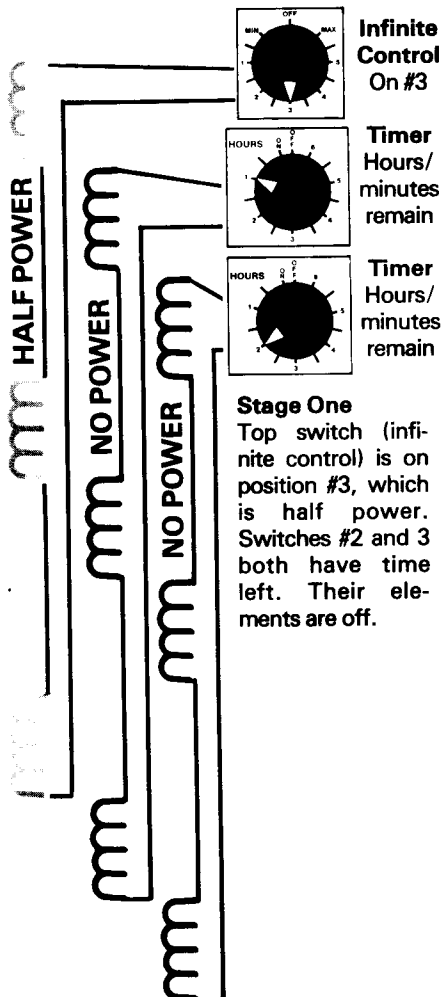

### STAGE TWO

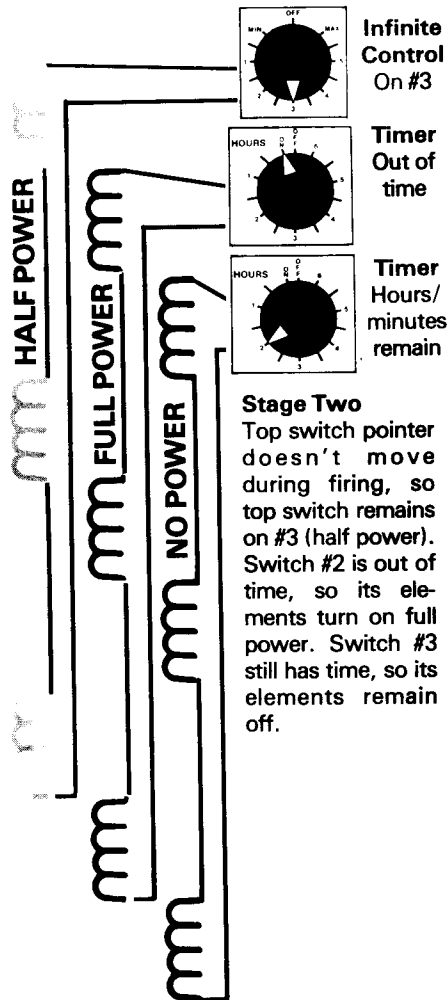

### STAGE THREE

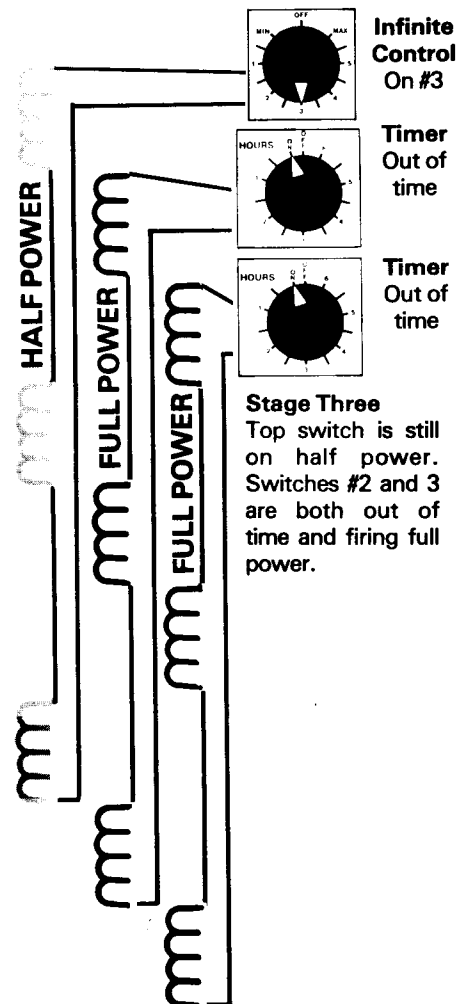

A fairly slow but even temperature climb is important in preventing breakage of the ware. Slow firing produces finer grained ware. Allow the kiln to cool to room temperature before opening the lid. Cooling time is usually twice the firing time.

**A Kiln's Clicking Sound**

Do not be alarmed when your kiln makes a clicking sound during firing. Infinite control switches on S and SnF-series kilns click as they cycle on and off until turned to high. The TnF-series kilns contain relays that click as they cycle on and off.

**S-Series Models**

S-Series kilns are manually operated and use infinite control switches. After the switch is turned on, the elements controlled by that switch cycle on and off. The higher the setting, the longer the elements stay on during each cycle. On HIGH (MAX) position, the elements stay on continuously.

If your S-series kiln has more than one switch, you can use the switches to help balance the heat in the kiln. The top switch controls heating elements in the top half of the kiln; the bottom switch controls heating elements in the bottom half of the kiln. If your kiln has three switches, the middle switch controls elements in the middle of the kiln. To add more heat to a section of the kiln, turn the switch for that section to high (MAX) position sooner.

**SnF-Series Models**

The SnF-series kilns fire in stages. Set the switches at the beginning of the firing, and the kiln will automatically go through its firing stages, turning itself up at the proper time. SnF kilns use the Kiln Sitter with Limit Timer as a shut-off device.

*WARNING: After the Kiln Sitter shuts the kiln off, turn all switches to their OFF position.*

**Understanding Your SnF Kiln**

The top switch is an infinite control. The heating elements connected to the top switch cycle on and off when the switch is turned on and Kiln Sitter is engaged. The higher the heat setting, the longer they stay on during each cycle. On MAX (maximum), the heating elements stay on continuously. The setting on the top switch remains the same throughout the firing unless you manually change it.

**Operating Instructions for SnF-Series Kilns**

These switch settings are only guidelines. Feel free to change them to suit your firing needs.

**SnF-82 & SnF-82-3**

- 1 Turn switches to their OFF position.
- 2 Insert desired cone in Kiln Sitter and load kiln.
- 3 Engage lid vent if desired.
- 4 Leave peephole plugs out.
- 5 Set Limit Timer for the total estimated firing time plus 15 minutes.
- 6 Engage Kiln Sitter.
- 7 Set switches to the positions indicated below:

- |                |                                  |
|----------------|----------------------------------|
| Cone 015 - 022 | • Set top switch to position #3. |
|                | • Set second switch to 1 Hr.     |

- |               |                                  |
|---------------|----------------------------------|
| Cone 04 - 014 | • Set top switch to position #4. |
|               | • Set second switch to 2 Hrs.    |

- |             |                               |
|-------------|-------------------------------|
| Cone 03 - 8 | • Set top switch to MAX.      |
|             | • Set second switch to 3 Hrs. |

**SnF-24, SnF-24-3 & SnF-28-3**

- 1 Turn switches to their OFF position.
- 2 Insert desired cone in Kiln Sitter and load kiln.
- 3 Engage lid vent if desired.
- 4 Leave peephole plugs out.
- 5 Set Limit Timer for the total estimated firing time plus 15 minutes.
- 6 Engage Kiln Sitter.
- 7 Set switches to the positions indicated below:

- |                |                                  |
|----------------|----------------------------------|
| Cone 015 - 022 | • Set top switch to position #3. |
|                | • Set second switch to 1 Hr.     |
|                | • Set third switch to 1 Hr.      |

- |               |                                  |
|---------------|----------------------------------|
| Cone 04 - 014 | • Set top switch to position #5. |
|               | • Set second switch to 1 Hr.     |
|               | • Set third switch to 2 Hrs.     |

- |             |                               |
|-------------|-------------------------------|
| Cone 03 - 8 | • Set top switch to MAX.      |
|             | • Set second switch to 2 Hrs. |
|             | • Set third switch to 2 Hrs.  |

**SnF-66 & SnF-66-3**

- 1 Turn switches to their OFF position.
- 2 Insert desired cone in Kiln Sitter and load kiln.
- 3 Engage lid vent if desired.
- 4 Leave peephole plugs out.
- 5 Set Limit Timer for the total estimated firing time plus 15 minutes.
- 6 Engage Kiln Sitter.
- 7 Set switches to the positions indicated below:

- |                |                                  |
|----------------|----------------------------------|
| Cone 015 - 022 | • Set top switch to position #2. |
|                | • Set second switch to 1 Hr.     |

- |               |                                  |
|---------------|----------------------------------|
| Cone 04 - 014 | • Set top switch to position #3. |
|               | • Set second switch to 2 Hrs.    |

- |             |                                  |
|-------------|----------------------------------|
| Cone 03 - 8 | • Set top switch to position #4. |
|             | • Set second switch to 3 Hrs.    |

## FIRING CONTROLS

The second switch is a timer. When you turn the pointer to a number, you are NOT turning on the heating elements for that switch. Instead, you are setting the timer for the hours of firing that will elapse before its elements turn on.

The third switch (if your kiln has one) is also a timer. The third switch begins counting down its time only when the second switch runs out of time.

When the timers run out of time, they click on. To turn them back off, turn clockwise one more click. Do this after the Kiln Sitter shuts off at the end of a firing.

In summary, the heating elements controlled by the top switch come on at the beginning of the firing. The elements powered by the second switch (and third, if your kiln has one) remain off until the timer runs out of time.

### **SnF-82 & SnF-82-3**

These kilns fire in two stages: LOW and HIGH. The top switch adjusts the amount of power during LOW, the first stage.

The second switch is a timer that times the length of firing on LOW. When its time is up, the second switch turns on stage two elements full power. The kiln is then firing on HIGH.

Look inside your kiln. It has eight rows of brick grooves each containing an element. Counting down from the top, switch #1 controls elements 2, 4, 6 and 8. Switch #2 controls elements 1, 3, 5 and 7.

### **SnF-24, SnF-24-3 & SnF-28-3**

SnF kilns with three switches fire in three stages: LOW, MEDIUM, and HIGH. Three-switch kilns operate the same as the two-switch kilns just described except that you add one more stage.

Look inside your kiln. It has 12 rows of brick grooves each containing an element. Counting down from the top, switch #1 controls elements 3, 6, 9 and 12. Switch #2 controls elements 2, 5, 8 and 11. Switch #3 controls elements 1, 4, 7 and 10.

### **SnF-66 & SnF-66-3**

These kilns have four elements. During stage one firing (LOW), the four elements are powered by the top switch. It is an infinite control. When the second switch runs out of time, the elements all turn on full power.

### **Changing Firing Speed of an SnF Kiln**

To fire slower, turn the top switch to a lower number and the 2nd (and 3rd) switch(es) to a higher number. To fire faster, turn the top switch to a higher number and the 2nd (and 3rd) to a lower.

## TnF-Series Models

### **The Basics**

#### **Which Instructions Apply to Your Controller**

The DTC 800C controller fires by Cone-Fire or Ramp-Hold. The DTC 800 fires in Ramp-Hold only.

Cone-Fire is a simplified method of firing to a pyrometric cone. Ramp-Hold, a little more advanced, allows you to adjust firing speed and temperature up to eight times during the firing.

### **Operation Begins from the IdLE Display**

The controller displays **ErrP** when you first plug in the kiln.

*On the DTC 800, the alarm sounds when you first plug in the kiln. To turn the alarm off, turn the safety switch on and press **ENTER**.*

Programming begins from **IdLE**. From **ErrP** or a flashing temperature, press any key (except **STOP**) to display **IdLE**. The safety switch (located near the display window) must be in the on position before **IdLE** will display.

If **FAIL** appears instead of **IdLE**, the thermocouple is either disconnected or burned out (see pg. 35).

### **Time and Temperature Display**

During time display, a center display period appears. During temperature display, the period disappears. The center display period separates hours from minutes (i.e. 1 hour and 30 minutes displays as 01.30).

*You can enter up to 99 hours and 99 minutes, displayed as 99.99. In this example, .99 would seem to be tenths and hundredths of hours, yet .99 is 99 minutes.*

### **How to Select °F or °C**

The controller operates in °F. or °C. temperature. In °C. display, a lighted period appears in the lower right, and in °F., it disappears. To switch from °F. to °C. or vice versa: from **IdLE**, touch **ENTER** then **0. CHG°** will appear. Touch **ENTER** again.

### **The Safety Switch**

**IdLE** will display only if the safety switch is turned on. When the firing is finished, **CPLt** will display alternating with the total firing time in hours and minutes. Cool-down temperature displays only after the safety switch is turned off.

*Turn the safety switch off after the kiln fires to completion. The switch is designed to prevent power flow to the kiln heating elements.*

### **Delay Fire**

The Delay Fire programs the kiln to begin firing later. It zeroes out after each completed firing, so if you want to use it for repeat firings, you will need to reset it each time. See Cone-Fire or Ramp-Hold firing instructions.

*WARNING: Never leave your kiln unattended near the end of a firing. We cannot guarantee your kiln against overfiring. Operator assumes full responsibility for shutting the kiln off at the proper time.*

### **Repeat Firings & Program Review**

To repeat the last firing, just press **ENTER** twice from **IdLE**. The kiln will begin firing. (This works for either Ramp-Hold or Cone-Fire.) But first, use Program Review to make sure you are using the correct program. To start Program Review from **IdLE**, touch **ENTER** then **6**. Values for the last program used will display one after the other. You can also use Program Review during firing simply by pressing **6**.

### **Power Failures**

After a brief power failure during firing, **PF** will appear in the display, alternating with temperature. Even though it displays **PF**, the kiln will continue to fire normally. The display shows **PF** simply to inform you



of a brief power failure. Press any key except **STOP** and normal temperature display will return.

When a firing has been interrupted by an extended power failure, **ErrP** will display when power returns. In addition, the DTC 800 controller (not the 800C) will sound a steady alarm.

With **ErrP** displayed after the power failure, press **ENTER**. The hours the kiln fired and temperature it reached before the power failed will appear. Then **IdLE** will display.

**Setting the Alarm From Idle**

The alarm beeps when a preset temperature is reached.

- 1 From **IdLE**, touch **ENTER** then **7**. **AlAr** will appear alternating with the last alarm temperature entered.
- 2 Enter alarm temperature. Then touch **ENTER**. **IdLE** will appear. (Enter **9999** to turn alarm off.)

When the alarm sounds during a firing, shut it off by pressing **ENTER**. (If it sounds as soon as the kiln begins firing, it is because the alarm was set to **0000**.)

**Setting the Alarm During Firing**

After you shut off the alarm during firing, you can set it to go off again later at either a higher temperature or a cool-down temperature.

- 1 The alarm beeps while the kiln is firing. Touch **7**.
- 2 Enter the new temperature.
- 3 Touch **ENTER**. The kiln will continue firing.

*Caution: if you touch 7, enter a new temperature, and forget to press ENTER, the firing will stop and the kiln will begin to cool down. You must press ENTER after entering the new alarm temperature.*

**Cone-Fire Mode**

This section is for DTC 800C boards, not DTC 800. The DTC 800 uses Ramp-Hold Mode only.

**Firing Speeds**

Cone-Fire fires at slow, medium or fast. Use **FAST** (1) for small, thin-walled ceramic greenware, overglazes, decals and china paint. Use **MEDIUM** (2) for larger, heavier pieces or tightly loaded kilns. Use **SLOW** (3) for hand-thrown pottery or porcelain.

**Hold (Soak) Time**

Hold means heat-soaking the ware at the end of the firing. You can hold the kiln at the final temperature for up to 99 hours and 99 minutes.

*CAUTION: Be very careful how you use Hold. It can easily overfire your ware.*

**Looking Up a Cone Temperature**

A feature called Cone Table can give you the temperature of a pyrometric cone. Do not be concerned, however, if your kiln's shut-off temperature for a cone does not match the temperature in the Cone Table. The temperature of a cone varies depending on firing speed.

- 1 From **IdLE** display, touch **ENTER** then **9**. **ConE** will appear, then the cone currently programmed in Cone-Fire Mode.
- 2 Enter the pyrometric cone number you are looking up. Then touch **ENTER**. The display will show the cone temperature. If you enter a non-existent cone number, the display will show **ConE**, ready for you to enter a different cone number.

**Cone-Fire Programming**

As the program prompts you for cone, speed, etc., you will see values entered for the last firing. To use these values again, just touch **ENTER**.

**To fire without Delay or Alarm features:** Follow steps 1 through 6 below. Then from **IdLE** press **START** twice.

- 1 Turn controller safety switch ON.
- 2 If controller displays **ErrP** or a flashing temperature, touch **ENTER**. **IdLE** will appear.
- 3 Touch **ENTER** then **1**. **ConE** will appear. Enter cone number.
- 4 Touch **ENTER**. **SPd** will appear. Enter speed: **FAST** (1), **MEDIUM** (2), **SLOW** (3).
- 5 Touch **ENTER**. **HLd** will appear. Enter hold time, if any, in hours and minutes (e.g. 12 hrs 30 mins = 12.30).
- 6 Touch **ENTER**. **IdLE** will appear.
- 7 To set alarm, touch **ENTER** then **7**. **AlAr** will appear. Enter alarm temperature. (Enter 9999 to turn alarm off.) Then touch **ENTER**.
- 8 To set delay fire, touch **ENTER** then **3**. **dELA** will appear. Enter delay time in hours and minutes (e.g. 12 hours 30 minutes = 12.30). Then press **ENTER**. (Delay zeroes out after each firing.)
- 9 To start program, touch **ENTER** twice. **-On-** will appear, then kiln temperature. If a delay was programmed, **-On-** will appear, then time remaining until start.

To stop the program during the firing cycle, touch **STOP** or turn the safety switch OFF. When program fires to completion, **CPLt** will appear alternating with total firing time in hours and minutes. Turn safety switch OFF when **CPLt** appears. To shut off the alarm when it sounds during a firing, press **ENTER**.

**Fine-Tuning Cone-Fire to a Shelf Cone**

Suppose firing in Cone-Fire does not match the bending of a pyrometric cone on the kiln shelf. You can use Cone-Fire Tuning to fire a little hotter or cooler to more closely match the shelf cone.

Cone-Fire Tuning can be set from 1 to 9. Normal firing is #5. The lower the number, the hotter the firing:

9	38° F. Cooler
8	26° F. Cooler
7	13° F. Cooler
6	6° F. Cooler
5 (Normal)	No Adjustment
4	5° F. Hotter
3	10° F. Hotter
2	15° F. Hotter
1	20° F. Hotter

## FIRING CONTROLS

To use Cone-Fire Tuning, **IdLE** must display. Press **ENTER**, then **1**. **ConE** will appear. Press **999**, **ENTER**. **rSLt** (for result) will display alternating with the current Tuning number. Enter the new number, then press **ENTER**. **ConE** will appear. Continue entering the values for the Cone-Fire program in the usual way. Once you change the Tuning number, Cone-Fire will remain adjusted to that number until you change it again.

The large cone on the kiln shelf should be visible through a peephole. Avoid exposure to cool air by keeping the cone at least 3" away from the peephole. Program the DTC 800C for the cone on the shelf and fire. After cooling, check the cone:

**The cone bent to 6 o'clock:** In this case, the controller is matched to your kiln.

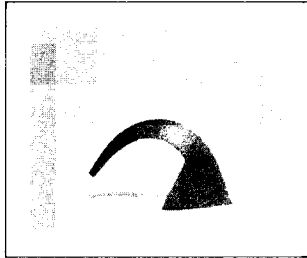

**The cone did not bend far enough:** Use a lower Tuning number for the next firing.

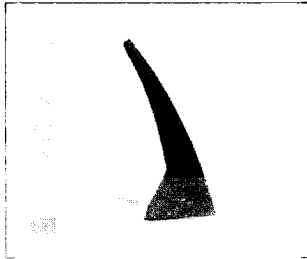

**The cone bent too far:** Use a higher Tuning number for the next firing.

*Do not be overly concerned with achieving an exact 6 o'clock bend. The difference between a 3 o'clock and a 6 o'clock bend is only a few degrees. Cones, even from the same box, also vary slightly.*

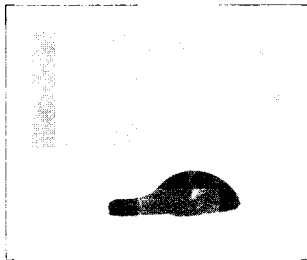

### Ramp-Hold Mode

Ramp-Hold is available on both the DTC 800C and DTC 800.

In Ramp-Hold, the kiln fires in segments, or stages. Each segment has a firing rate, firing temperature, and hold (or soak) time. Ramp-Hold includes eight segments. Use only the number of segments you need per firing, from one to eight.

Rate is degrees of temperature change per hour, from 1° to 9999°F. (e.g., to increase temperature by 500° per hour, enter a rate of 500).

To control cooling, set the segment to a lower temperature than that of the preceding segment.

### Storing User Programs in Ramp-Hold

A user program is a set of firing instructions to run the kiln in Ramp-Hold. A user program includes number of segments needed; firing rate, temperature, and hold (if any) for each segment; and an alarm temperature (if any).

## Ramp-Hold Programming

As the program prompts you for segments, rate, temperature, etc., you will see values from the last firing. To use these again, just touch **ENTER**.

**To fire without the Delay feature:** Follow steps 1 through 9. Then press **START** twice.

**1** Turn controller safety switch ON.

**2** If controller displays **ErrP** or a flashing temperature, touch **ENTER**. **IdLE** will appear.

**3** Touch **ENTER** then **4**. **USER** will appear. Enter a number from 1 to 6 for the stored program desired.

**4** Touch **ENTER**. **SEGS** will appear. Enter number of segments you will use.

**5** Touch **ENTER**. **rA 1** will appear. Enter firing rate for segment 1 (temperature change per hour: any temperature from 1° to 9999° F.).

**6** Touch **ENTER**. **F 1** will appear. Enter the temperature you will be firing to in segment 1.

**7** Touch **ENTER**. **HLd1** will appear. Enter segment 1 hold (soak) time in hours and minutes (e.g. 12 hours and 30 minutes = 12.30).

**8** Touch **ENTER**. Continue entering values for all segments.

**9** Touch **ENTER**. **AlAr** will appear. Enter alarm temperature. (Enter 9999 to turn alarm off.) Then touch **ENTER**.

**IdLE** will appear.

**10** To set Delay Fire, touch **ENTER** then **3**. **dELA** will appear. Enter delay time in hours and minutes (e.g. 12 hours and 30 minutes = 12.30). Then touch **ENTER**. (Delay zeroes out after each completed firing.)

**11** To start program, touch **ENTER** twice. **-On-** will appear, then kiln temperature. If a delay was programmed, **-On-** will appear, then time remaining until start.

To stop the program during the firing cycle, touch **STOP** or turn the safety switch OFF. When program fires to completion, **CPLt** will appear alternating with total firing time in hours and minutes. Turn safety switch OFF when **CPLt** appears. To shut off the alarm when it sounds during a firing, press **ENTER**.

Ramp-Hold can store up to six user programs even when the kiln is unplugged. Potters may want to store a program for crystalline glaze, another for a favorite red glaze, etc. Glass artists might want to store several programs for fusing their favorite types of glass and another for slumping.

When you enter Ramp-Hold mode, the first prompt to appear is **USER**. The **USER** prompt means, "Select a stored user program for this firing". If you are using Ramp-Hold for the first time, press 1. Then enter num-

ber of segments, firing rate, temperature, etc. (see instruction box). Each time you add another program to storage, select the next available number, such as 2, at the **USER** prompt.

To use a stored program, select the program number at the **USER** prompt. Press **ENTER**. If there are no changes to the program, press **STOP**. A flashing temperature will appear. Press **ENTER**. **Idle** will appear. The controller is ready to fire the program you selected. (We suggest using Program Review before firing a stored program; see page 13.)

### **Hold (Soak) Time**

"Hold" means heat-soaking the ware at the end of the segment. You can hold the temperature in each segment for up to 99 hours and 99 minutes.

### **Present Status**

Present Status shows which segment the kiln is in while firing. This is especially useful for firings that have heating-up and cooling-down segments. To use Present Status, press **5** during a firing. The current segment will display momentarily.

### **Skip Segment**

Skip Segment works only during firing. To skip a segment, press **9**. **SStP** will display. (If you change your mind and don't want to skip that segment, do nothing and the firing will continue as it was.) If you still want to skip the segment, press **ENTER**. **rA** will appear along with the segment number you just skipped to.

### **What To Do When Your TnF Kiln**

#### **Shuts Off Too Early**

You can turn the TnF-series kiln back on if it shuts off before the shelf cone bends. We will assume you are near your kiln when it shuts off. **CPLt** appears in the display. To continue firing:

**1** Turn the controller safety switch off and then back on.

**2** Run the same program again. This time, however, fire to a hotter cone or higher temperature. Or just add hold time to the end of the firing. Re-enter the program. As the controller prompts you for cone and speed or segments, rate and temperature, it will show the last entry that was programmed. Just touch **ENTER** to leave a value unchanged.

**3** After you change the program, the controller will return to **Idle**. Press **ENTER** twice to resume firing. The controller will take up where it left off.

## LOADING THE KILN

### **Kiln Furniture**

#### **Shelves**

Shelves are flat slabs of fireclay that have been fired to a higher temperature than will be encountered in your kiln. By using shelves you can stack more ware in your kiln than you could ever place on the bottom of the kiln alone.

Half shelves increase kiln space by making it possible to fire tall pieces on one side of the kiln and one or more layers of small items on the other side.

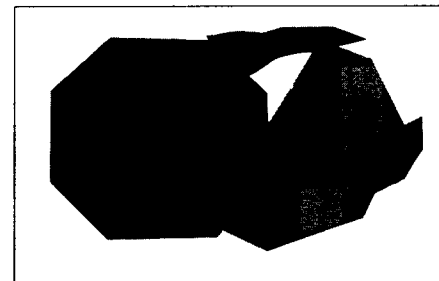

Shelves are strong and will not sag if properly supported and not overfired. But like any other pottery, they will break if dropped.

#### **Posts**

Posts are made from the same material as shelves. Posts support and separate the layers of shelves in a kiln. The shorter the post, the greater the stability. Posts can be stacked upon one another to achieve a certain height, but a single post of the same height is more stable.

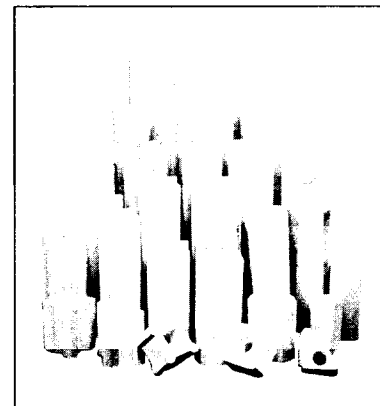

1/2" and 1" posts are used to obtain heights not in your post assortment. Avoid using posts taller than 10" by placing tall ware on the top shelf of your kiln.

#### **Stilts**

Stilts prevent ware from sticking to the shelves during firing. They are used mainly for glazed ware and can be used in firings up to 2000° F.

Stilt points are made of a high temperature metal alloy. You can straighten metal points by bending gently with pliers. Glaze buildup on the points can be removed with a stilt stone. Stilts come in a wide variety of shapes for firing different objects. Be sure the stilt you select will support your ware to prevent the piece from toppling over during firing.

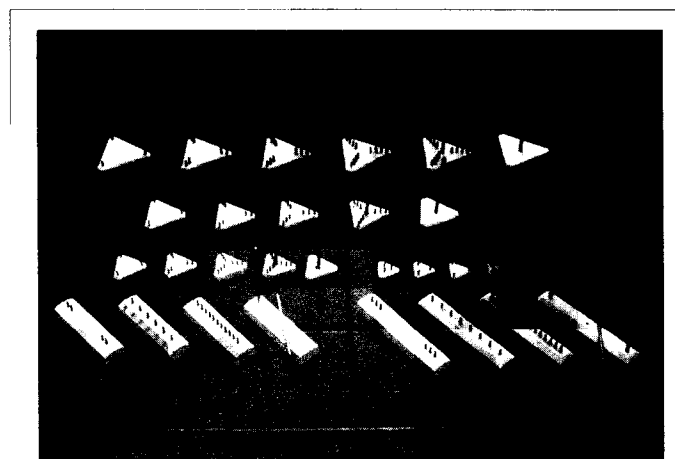

## LOADING THE KILN

### Recommended Furniture Kits

Furniture kits are carefully selected assortments of shelves and posts to allow you to make the most of your kiln's firing capacity. *NOTE:* Shelves should be 1 to 2 inches smaller than the firing chamber of the kiln. If shelves are larger, breakage may occur.

#### S-11-9-3

1 C-10 Shelf; 1 C-10H 1/2 Shelf  
1" Square Posts, 3 each - 1", 2", 3"  
1 lb. Bag Kiln Wash  
*Shpg. Wt.: 10 lbs.*

#### S-23-3, TnF-23-3

6 C-23H 1/2 Shelves  
1 1/2" Square Posts, 8 each - 1", 2", 3", 4", 5", 6"  
1 lb. Bag Kiln Wash  
*Shpg. Wt.: 77 lbs.*

#### S-24, SnF-24, TnF-24, S-99

8 C-22H 1/2 Shelves  
1 1/2" Square Posts, 8 each - 1", 2", 3", 4", 5", 6"  
1 lb. Bag Kiln Wash  
*Shpg. Wt.: 118 lbs.*

#### S-24-3, SnF-24-3, TnF-24-3

8 C-23H 1/2 Shelves  
1 1/2" Square Posts, 8 each - 1", 2", 3", 4", 5", 6"  
1 lb. Bag Kiln Wash  
*Shpg. Wt.: 94 lbs.*

#### TnF-27L-3

6 C-24H 1/2 Shelves  
1 1/2" Square Posts, 6 each - 1", 2", 3", 4", 5", 6"  
1 lb. Bag Kiln Wash  
*Shpg. Wt.: 150 lbs.*

#### S-28-3, SnF-28-3, TnF-28-3

8 C-24H 1/2 Shelves  
1 1/2" Square Posts, 8 each - 1", 2", 3", 4", 5", 6"  
1 lb. Bag Kiln Wash  
*Shpg. Wt.: 164 lbs.*

#### S-66, SnF-66, TnF-66

2 C-13 Shelves; 1 C-13H 1/2 Shelf  
1" Square Posts, 3 each - 1/2", 1", 2", 3", 4", 6"  
1 lb. Bag Kiln Wash  
*Shpg. Wt.: 21 lbs.*

#### S-66-3, SnF-66-3, TnF-66-3

2 C-14 Shelves; 1 C-14H 1/2 Shelf  
1" Square Posts, 3 each - 1/2", 1", 2", 3", 4", 6"  
1 lb. Bag Kiln Wash  
*Shpg. Wt.: 20 lbs.*

#### S-82, SnF-82, TnF-82

3 C-16 Shelves; 1 C-16H 1/2 Shelf  
1" Square Posts, 4 each - 1/2", 1", 2", 3", 4", 5", 6"  
1 lb. Bag Kiln Wash  
*Shpg. Wt.: 50 lbs.*

#### S-82-3, SnF-82-3, TnF-82-3

3 C-18 Shelves; 1 C-18H 1/2 Shelf  
1" Square Posts, 4 each - 1/2", 1", 2", 3", 4", 5", 6"  
1 lb. Bag Kiln Wash  
*Shpg. Wt.: 34 lbs.*

#### S-99

(Same as S-24, SnF-24, TnF-24)

#### S-100

6 C-22H 1/2 Shelves  
1 1/2" Square Posts, 8 each - 1", 2", 3", 4", 5", 6"  
1 lb. Bag Kiln Wash  
*Shpg. Wt.: 100 lbs.*

#### S-1613-3, TnF-1613-3

2 C-18 Shelves 1 C-18 1/2 Shelf  
1" Square Posts, 3 each 1/2", 1", 2", 3", 4", 6"  
1 lb. Bag Kiln Wash  
*Shpg. Wt.: 28 lbs.*

## All Purpose, High Fire Kiln Wash

High fire kiln wash is a mixture of finely ground minerals that will not melt and fuse together at porcelain temperatures. It is a powder that is mixed with water to the consistency of thick cream. Brush a thin, even coat on the tops of kiln shelves and on the kiln bottom to prevent glaze drippings from sticking permanently to these surfaces. As a powder, high fire kiln wash has an unlimited shelf life.

Never use a regular ceramic type kiln wash, because after applying ceramic kiln wash and firing the kiln above cone 04, the kiln wash will harden and be difficult, if not impossible, to remove later when you want to fire to hotter temperatures. All purpose, high fire kiln wash *MUST* be used in all kilns rated to 2300°F., even though the kiln is usually fired at lower temperatures.

While you need not recoat with kiln wash after each firing, scrape glaze drops off the shelves or dig them out of the bottom as soon as they appear. Then apply a new coat of kiln wash to the bare area.

*Keep kiln wash away from elements. Contact with kiln wash burns out elements!*

When you brush kiln wash onto the kiln bottom, protect the kiln walls and elements from kiln wash with a piece of cardboard. *Never apply kiln wash to kiln walls or to the underside of shelves.*



## Guidelines for Loading the Kiln

*S & SnF MODELS: Before loading your kiln, insert the cone in the Kiln Sitter (see page 7). Double-check the number stamped on the cone.*

*ALL MODELS: Brush all purpose, high fire kiln wash onto the kiln bottom and tops of shelves.*

**1** To make full use of your kiln's firing capacity, group similar sizes of ware together inside the kiln. (Begin grouping similar sized ware as you prepare the ware and lay it out to dry prior to firing.)

**2** Place small, light pieces directly on the floor of the kiln. Leave ample room for air to circulate around their bases.

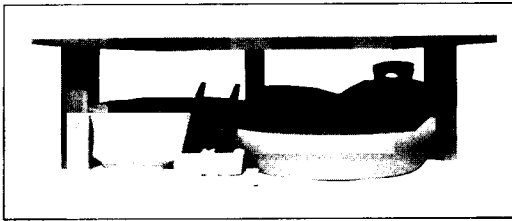

Small, light pieces of greenware can be placed directly on the brick bottom.

**3** A good place for tall pieces is the top shelf, with no posts or shelves above them.

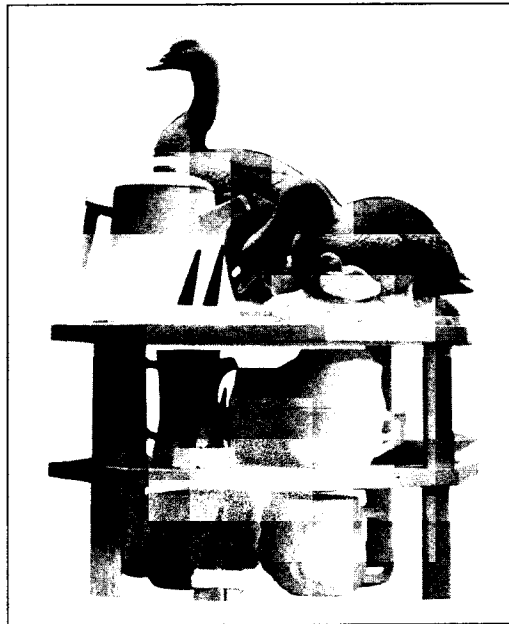

**4** Leave at least two element grooves between the floor of the kiln and the first shelf.

**5** Keep ware at least one inch away from any heating element. If you fire a piece that is so large that a tip of it comes closer than one inch to a kiln wall, place that section of the piece between elements.

**6** Large, heavy greenware pieces will fire best if placed across two half shelves positioned at an even height.

**7** Stack posts so that they are directly in line with each other vertically. (See drawing below.) If posts are stacked vertically offset from each other, shelves will be less stable.

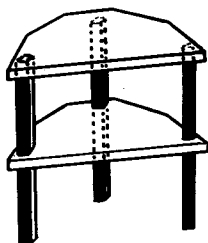

Correctly Positioned

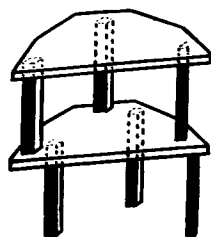

Incorrectly Positioned

**8** The minimum spacing between shelves is 2 1/2". You can achieve this minimum 2 1/2" height by stacking a 1/2" long post on top of a 2" long post.

**9** Shelves must be stacked so there is at least one row of heating elements between any two shelves.

**10** The posts used with each layer of ware should be at least one inch taller than the ware.

**11** Keep all ware and kiln shelves at least 1/2" away from the side, top and bottom of the end of the Kiln Sitter actuating rod or TnF thermocouple.

**12** Make sure at least one element groove is between the top shelf and the top of your kiln.

**13** We urge the use of at least one large pyrometric cone behind the peephole on a kiln shelf in every firing. Place cones 3 inches from the peephole to prevent exposure to cool air. Check the cone through the peephole before placing a shelf over it.

**14** Hold a shelf by two edges and lower it carefully into the kiln to prevent damaging sidewall firebrick. Be careful not to jar the kiln after loading, or the ware or a shelf could fall over and break. Shelves should be 1 to 2 inches smaller than the kiln firing chamber.

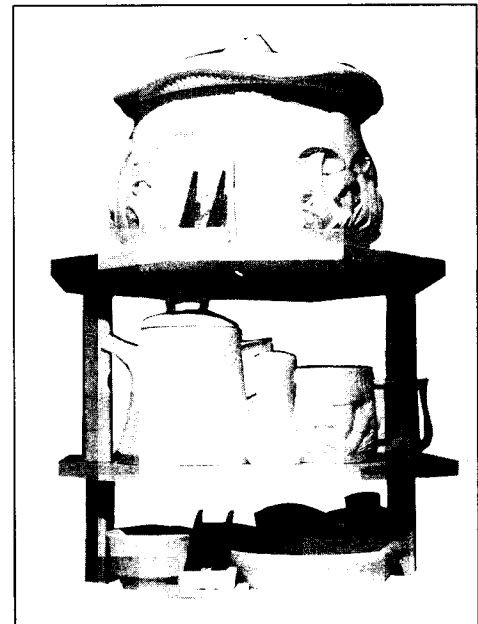
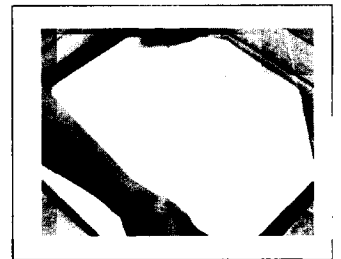

## COLOR SCALE FOR TEMPERATURES

Color	Appx. Cone	Degrees F.
Lowest visible red to dark red	022 to 019	885 to 1200
Dark red to cherry red	018 to 016	1200 to 1380
Cherry red to bright cherry red	015 to 014	1380 to 1500
Bright cherry red to orange	013 to 010	1500 to 1650
Orange to yellow	09 to 03	1650 to 2000
Yellow to light yellow	02 to 10	2000 to 2400

# FIRING YOUR KILN

## Important Features

### Firebrick

We use only premium insulating firebrick in your kiln. However, kiln brick is fragile. Never let a shelf bump against the firebrick. Firebrick damage is not covered by warranty.

The temperature required for ceramics is well above the melting point of most metals, and tremendous stresses are generated during firing. Insulating firebrick expands and contracts with each firing, a process that is absolutely necessary for the long life of your kiln. In time, hairline cracks will appear in the brick while the kiln is cold. Do not be alarmed; the cracks close tightly during the next firing. They function as expansion joints and will not harm your kiln's operation.

### Elements

Elements are brittle after being fired and will break if you bend them while they're cold. Contact with foreign materials such as glaze and kiln wash can destroy elements. This type of element failure is not covered by warranty.

### Peepholes

The peepholes in your kiln are tapered for a wide view without heat loss. You can observe the progress of your firing by watching

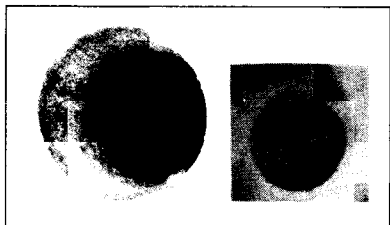

pyrometric cones through the peepholes. Use at least one large cone on the shelf during every firing—even in a TnF kiln.

You can leave the peephole plugs out for some firings. An advantage to leaving the peephole plugs out during firing is better oxygenation inside the kiln. A disadvantage is that it can cause cold spots in the kiln, especially if there are air drafts in your firing room. If you leave the peephole plugs out, keep ware at least 3" from the peephole. If your ware develops problems from cool air drafts, such as a glazed piece with a crazed spot, insert the peephole plugs after the kiln reaches 1000° F., or about half way through the firing. If you use an Orton KilnVent, keep peephole plugs inserted for the entire firing.

Always wear Paragon firing safety glasses when looking through the peepholes. They protect your eyes from the heat and light of the kiln and also make it easier to see the cones.

### Prop-R-Vent

Paragon's fall away Prop-R-Vent vents the lid in two stages. To close the lid after venting, lift the lid handle an inch. The Prop-R-Vent will fall down by itself. Lower lid gently; warranty does not cover damage to kiln or ware due to a dropped lid.

Ceramic pieces release gases and water vapor during firing. Venting allows these gases to escape. For lusters and overglazes, engage the Prop-R-Vent in its second position for additional venting.

Do not rush the cooling of your kiln with the Prop-R-Vent. This can damage your ware.



## Your First Firing

For your first firing, fire to cone 01. A cone 01 firing is hot enough to soften the elements and seat them properly in their recessed grooves. It will also form a good oxide coating on the elements for longer element life.

Foreign materials interfere with the formation of this oxide layer. So for your first firing, position only your kiln-washed shelves in your kiln with pyrometric cones placed in front of a peephole. Air must circulate around the empty shelves, so separate them with posts. The shelves may crack if you stack them in your kiln without separating them.

- 1 Seat the elements in their grooves by performing the kitchen knife test (page 3).
- 2 Empty the kiln and clean with the brush attachment on a vacuum cleaner.
- 3 Apply Paragon all-purpose, high fire kiln wash to the kiln bottom and the tops of shelves (page 17).
- 4 S & SnF-series: Adjust and test the Kiln Sitter (pages 5 & 6). Insert an 01 small cone on the Kiln Sitter cone supports. (Reminder: remove and save the firing gauge.)
- 5 Load the shelves into the kiln, separating them with posts. Do not load ware into the kiln for this first firing. Place an 01 large cone on a shelf where it can be seen through a peephole.
- 6 Prop the lid with the Prop-R-Vent. (Close the lid after one hour.) Leave the peephole plugs out of the peepholes. Fire your kiln referring to "Firing Controls," pages 11 - 16, for your kiln series.

Monitor the kiln closely during this first firing. Look at the cone through the peephole periodically. (Be sure to wear firing safety glasses.) When the shelf cone bends to 6 o'clock, the kiln should shut off. If it doesn't shut off, turn it off within 10 minutes. Make a note of how long the firing takes. This will help you predict future firing times. After the kiln shuts off, leave the lid closed until the kiln has cooled to room temperature. Cooling time is usually twice the firing time.

*Always make sure the kiln has shut off before leaving it unattended. Do this with every firing!*



## Drying Greenware

Ordinarily, do not use the kiln to dry greenware. Moist greenware is expensive to fire. The moisture rusts the kiln's steel base and other parts; wears out elements faster; uses a lot of electricity; and can explode inside the kiln.

In very humid areas, though, it is sometimes difficult to dry greenware completely before firing. The following suggestions will help solve this problem:

**1** Give the greenware enough time to dry. In most areas, it takes at least two days to dry greenware. Drying time depends on humidity.

**2** Touch the greenware to the inside of the wrist or to the cheek. If it feels warm, it is usually dry. *Dry longer if it feels cool.* (Note that in humid areas, even damp greenware can feel warm. The humidity causes the moisture in the greenware to stop evaporating.)

**3** If you live in a humid area and the greenware is still moist after an extended drying time, load it into the kiln. Prop the lid with the Prop-R-Vent. Fire to 200° F. slowly. Maintain 200° F. until the greenware is completely dry—usually several hours.

To maintain 200° F. in the kiln:

**TnF-series:** Use Ramp-Hold mode.

**S-series:** Turn the bottom switch on MIN (low), leave the other switches off.

**SnF-series:** Turn the top switch to MIN. Leave time on the other switches so their elements remain off.

### Testing for Dryness with a Mirror

Hold a mirror above the top peephole for a few seconds where hot air from the kiln will move across the mirror's surface. If the mirror fogs, the greenware is still releasing moisture. Keep the lid propped and maintain 200° F. until the mirror no longer fogs. (If you are firing with an Orton KilnVent, first turn off the KilnVent. Then perform the mirror test.)



Hold a mirror above the top peephole. Fogging indicates moisture.

The mirror must be at room temperature for this test. The mirror fogs when moisture in the hot air condenses on the cooler mirror. If you hold the mirror too long near the kiln, the mirror will heat up and will no longer fog when moisture hits it. So hold it at the lid for only several seconds at a time.

## Loading & Firing Low-Fire Greenware

Low-fire greenware has a firing range from cone 06 to 02. The greenware must be bone dry before firing. Otherwise, it will crack or even explode during firing. Check for dryness by touching to cheek or against inside of wrist. Ware will be cold if not dry.

Low-fire greenware may be stacked so that it touches each other. It can be loaded without stilts. Load small,

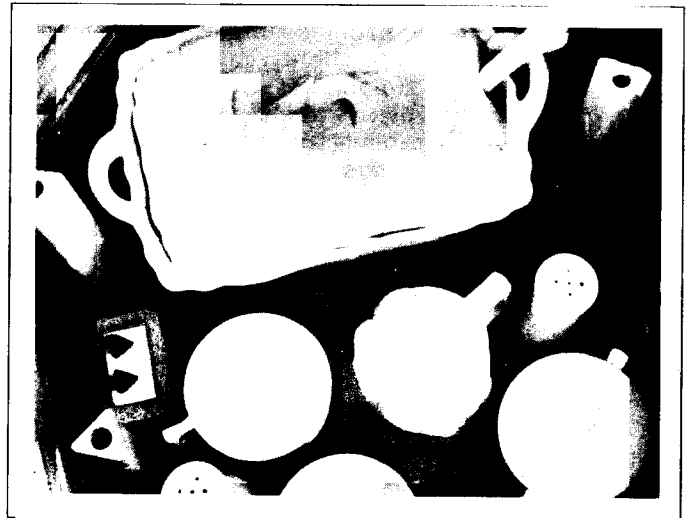

Ware to be used together should be fired together in the greenware firing. In this photo, two sizes of greenware are loaded directly on kiln's floor. Half shelves will be placed over the greenware at different heights.

short pieces directly on the firebrick bottom. If you load large, flat pieces on the firebrick bottom, place short posts under them for air circulation. Large, heavy pieces of greenware will fire best if placed across two half shelves positioned at an even height. This allows air to circulate under them. To make full use of kiln's capacity, place ware of the same height in each layer.



Large flat pieces may be placed on kiln's floor if short posts are used to allow heat circulation.

Fire ware in the position in which it will be used when finished, except for large pieces with flat, vertical surfaces such as wall plaques and clocks. These should be fired flat to prevent warping. Pieces to be used together, such as a box with its lid, should be fired in place to ensure a good fit.

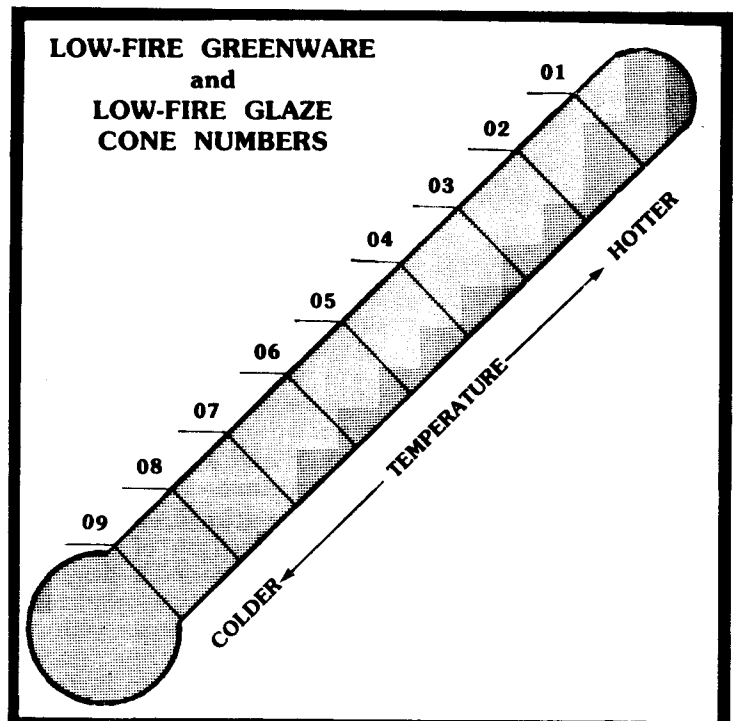

## FIRING YOUR KILN

Low-fire greenware firing is simple. Just be certain the greenware is fired to the pyrometric cone recommended by the clay supplier. If the greenware is not fired hot enough, the piece will absorb moisture after it has been glaze-fired, causing the glazed surface to crack. This is called "crazing" and is most often due to under-fired greenware. To help eliminate crazing, fire greenware at least one cone hotter than glaze, and even hotter if glaze can still be applied easily to the hard bisque. While glaze may be applied to greenware and fired once, separate firings produce better quality, so we do not recommend single firing of greenware and glaze.

Peephole plugs are supplied with your kiln. However, it is not necessary to use them. If you use them, leave them out for the first half of firing. Allow kiln to cool to room temperature before opening lid.

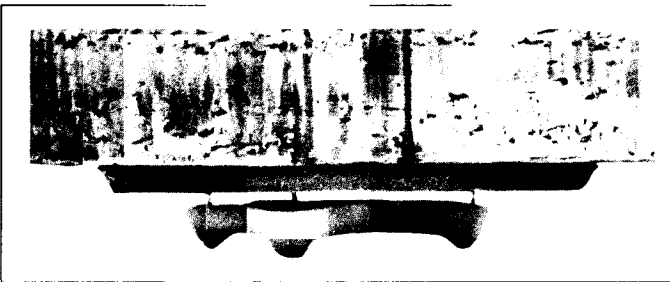

Glazed pieces will stick to the kiln floor or shelf unless stilted or "dry footed."

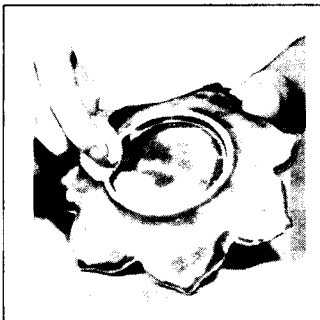

"Dry footing" a piece of unfired glazed ware.



Sharp points left from stiling glazed ware are removed with stilt stone.

### Loading and Firing Low-Fire Glaze

Prop-R-Vent holds the lid in its venting position so gases and water produced by the ware can escape.

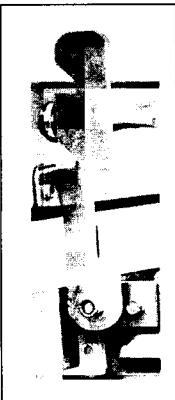

The difference between loading greenware and glazed ware is that glazed pieces must not touch each other, the floor or a shelf in your kiln during firing. If this happens they will be permanently bonded together and ruined by the melted glaze.

The natural expansion and contraction of the insulating firebrick during each firing generates tremendous stresses within the firing chamber. As a

result, fine grains of firebrick may form on the surface of the sidewalls and should be removed before each

firing. Wipe the sidewalls with a clean, damp cloth or vacuum the sidewalls with the soft brush nozzle attachment of a vacuum cleaner.

Use stilts to support low-fire glazed ware during firing. The shelf tops and kiln floor *MUST* be kiln washed with all purpose, high fire kiln wash for protection from glaze drops. Never use a ceramic kiln wash in a kiln suitable for firing porcelain.

Glazed pieces must be thoroughly dry before firing and should not be fired with greenware unless both mature at the same cone. Even then, separate the glaze from the greenware by loading glazed pieces in the bottom of the kiln and greenware on shelves above. Low-fire glaze usually fires to a lower cone than greenware, so firing time will be shorter if glazed pieces are loaded separately.

Check to make sure that first, no two pieces of glazed ware are touching each other, the kiln walls, the floor or the shelves; and second, that the underside of the kiln shelf is clean before you place it over glazed pieces. Any dust falling on your ware will cause pinholes.

You can prevent glazed pieces from sticking to the shelf or kiln bottom by "dry footing." To "dry foot" a piece, remove all glaze from the portion of the piece that will rest on the shelf. Using a wet sponge or a piece of grit cloth, clean off the glaze from the bottom of the ware and slightly above the base so that it will not run down and touch the base. Do not use dry footing for low-fire glazed pieces that will be placed in water while used or cleaned.

Peephole plugs are supplied with your kiln. However, it is not necessary to use them. If you choose to use them, insert them only after the first half of the firing.

If you are firing ware draped with lace, venting through the hole drilled in the lid may not be sufficient. Prop the lid with the Prop-R-Vent until all smoke disappears. After firing, allow kiln to cool to room temperature before opening lid.

Remove the stilts from the ware after firing by breaking the thin film of glaze holding them. Handle with caution. Remove the sharp stilt edges by rubbing with a stilt stone, electric grinder or hand grinder.

### Loading and Firing Porcelain Greenware

Porcelain greenware refers to clay bodies that mature at a point between cones 4 to 10. Porcelain is vitreous, and the white color will usually show the shadow of the hand if held up to a strong light.

Loading porcelain greenware is similar to loading glazed ware, since both will stick to anything during firing. Greenware must be completely dry before firing, including the joints on pieces that are attached. If a piece is broken before firing, mend the break but do not attempt to fire it until the mend is also bone dry. Damp greenware or damp mended areas will form bumps on the surface of the fired ware.

Stilts *CANNOT* be used to support porcelain greenware. They would embed into the porcelain at high temperatures. To protect porcelain from sticking to the shelves or kiln floor, apply a coat of all purpose, high fire kiln wash to the shelf tops and brick bottom. Then place your ware directly on the kiln washed surfaces.

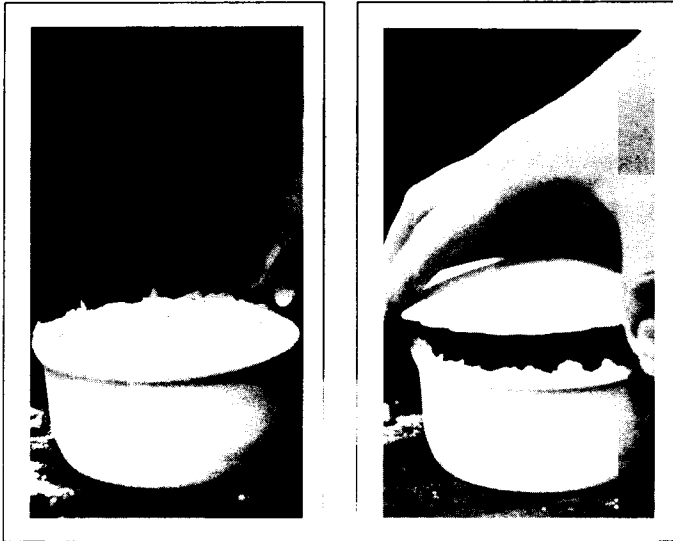

High fire kiln wash will keep porcelain greenware that must be fired together from sticking. The kiln wash should be dry. Wet kiln wash is difficult to remove after firing.

*Never use ceramic kiln wash in a kiln that will ever be fired to porcelain temperatures, as the ceramic kiln wash will harden at high temperatures and be impossible to remove.*

Pieces of ware that are to be used together must be fired together, such as a box and its lid. Dry all purpose, high fire kiln wash can be used to separate these pieces during firing. Wet kiln wash would be too difficult to remove.

Pieces likely to warp in firing should be supported by rolls of porcelain clay shaped to fit the objects at points of strain. Apply dry silica or high fire kiln wash to the points of contact to prevent sticking. Before firing, the support rolls must also be bone dry.

Since a kiln is slightly hotter near its sidewalls, the side of the ware next to the walls will tend to shrink more than the opposite side. This can be used to your advantage with porcelain figurines that tend to warp during firing. Turn the inclined side of the figure away from the elements so the heat can help hold the piece straight.

Make sure cones on the shelf are clearly visible. At porcelain temperatures, they are difficult to see. It is not necessary to use peephole plugs. If you decide to use them, leave them out until the firing is half over. If you are firing ware draped with lace, you may need to vent the lid with the Prop-R-Vent. Lower the lid fully after all smoke disappears. Allow kiln to cool to room temperature before opening lid.

## Loading and Firing Porcelain Glaze

Loading porcelain glaze is similar to loading porcelain greenware. Place lightweight ware and small pieces on the kiln bottom. For good heat circulation, keep them at least 3/4" from the sidewalls.

Porcelain pieces that have been fired together in the greenware firing *cannot* be fired together in the glaze firing. Both pieces *must* be "dry footed". Since shrinkage has already occurred in the greenware firing, the pieces will still fit even when fired separately in the porcelain

glaze firing. Stilts *must not* be used to support porcelain. Porcelain softens during firing, and stilts would embed into porcelain. Make sure your shelves and kiln bottom have a good coat of kiln wash before firing porcelain.

If a piece of ware had to be supported in the porcelain bisque fire, it will stand alone in the glaze fire. The lower temperature will prevent sagging.

Allow kiln to cool to room temperature before opening lid. Cooling time is usually twice the firing time.



Glazed porcelain pieces are never supported by stilts. Instead, each piece must be dry footed. A sponge is used in this example to remove the glaze from the bottom of the piece.

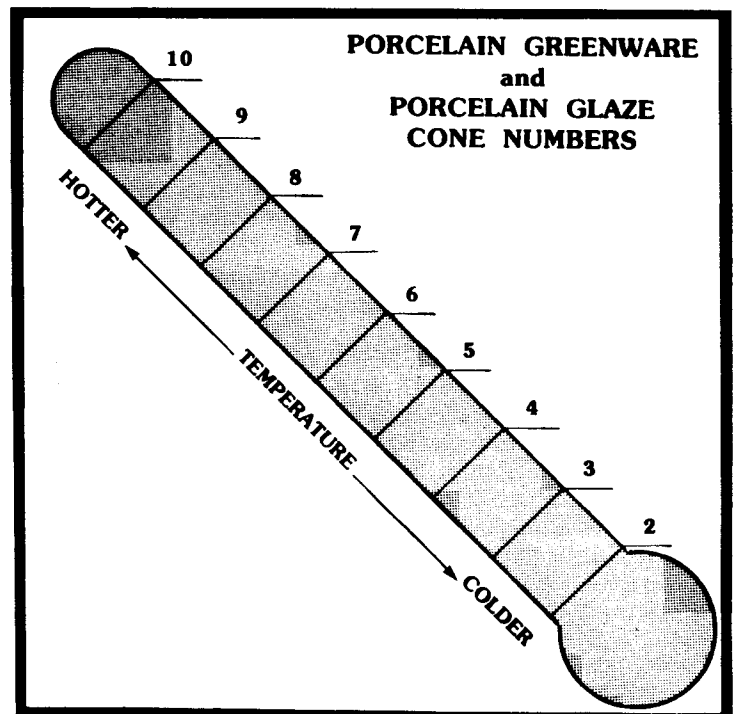

## FIRING YOUR KILN



Porcelain glaze is dry footed and placed directly on the kiln-washed shelf or brick bottom. Pieces that were fired together in the greenware firing cannot be fired together in the glaze firing, and it is not necessary to support the ware with rolls of porcelain clay.

Prop-R-Vent engaged in its extended position for the venting of lustres and other overglazes.

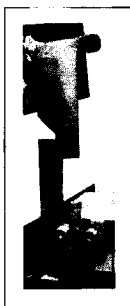

### Loading and Firing Overglaze

Overglaze is decoration applied over fired glaze or polished porcelain bisque. Overglazes include china paints, gold, and luster, which fire from 022 to 014.

Load overglazed ware the same way you would load ceramic glaze. Use stilts and

make sure ware is not touching other ware. Ware must be completely dry before firing.

China paints will crack or peel if applied heavily. Apply several light coats instead, firing between each, until you get the shade you want. Not all china paint colors reach maximum color saturation at the same temperature even when fired on the same ware. So you must know which colors you should fire first at higher temperatures to prevent burning out the original colors in later firings. For example, reds mature at a lower temperature than other colors and are fired after the other colors have been fired. Do not fire reds and yellows side by side. Colors also mature at a lower temperature on ceramic pieces than on porcelain or hard china. Check the overglaze manufacturer's literature for information on which cone to use with each color and type of ware.

Plates fire better when supported by a plate holder or placed on edge to permit even heating. If fired on edge, plates may be supported at the bottom with large spur

stilts, which can also be used to separate adjoining plates. Tall posts can be used to prevent plates from touching the kiln wall.

China painted plates stacked on edge and separated by stilts.



Plateholders ensure even firing of china painted plates.

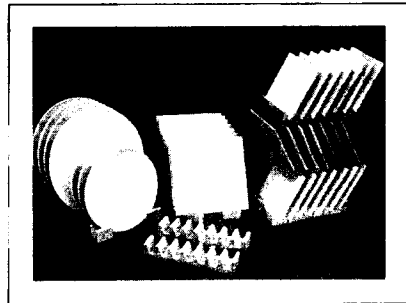

Position plates between elements for good heat distribution.

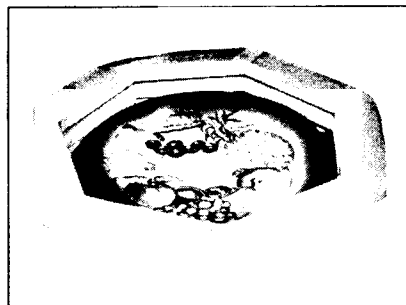

### OVERGLAZE CONE NUMBERS

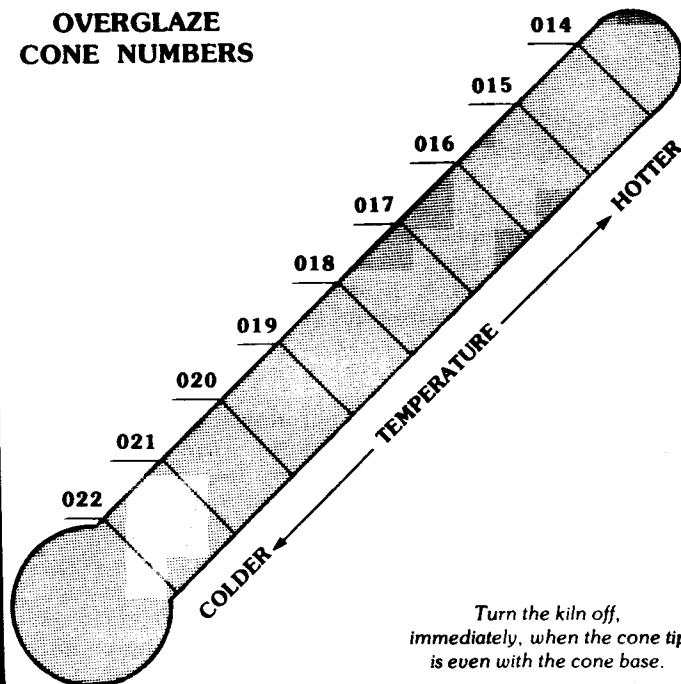

Turn the kiln off, immediately, when the cone tip is even with the cone base.

Overglaze may require extra venting with the Prop-R-Vent until all odor from china paint oil and other organic materials has vanished. How long this takes depends on how much decoration is on the ware. Vent at low temperatures. Allow kiln to cool to room temperature before opening lid.

## Loading and Firing Stoneware Greenware or Glaze

Stoneware is made from vitrifiable clays with a firing range of cone 2 to cone 10. It has a wide range of colors and textures and is popular with the potter because of its excellent throwing qualities. Usually the greenware is fired below maturity, and on the second firing, the clay and glaze mature together to form an integrated body-glaze surface.

Like porcelain greenware, stoneware is placed directly upon the kiln-washed shelves in the greenware firing. Place small items on the kiln bottom and large, heavy pieces across two half shelves.

Glazed stoneware must not touch any other ware and must be dry footed before you place it on a kiln-washed shelf or kiln bottom. Never stilt stoneware during either firing.

Glazed stoneware must not touch any other piece on a kiln-washed shelf or the brick bottom.



Large, heavy pieces of glazed stoneware will fire best if placed across two half shelves positioned at an even height.

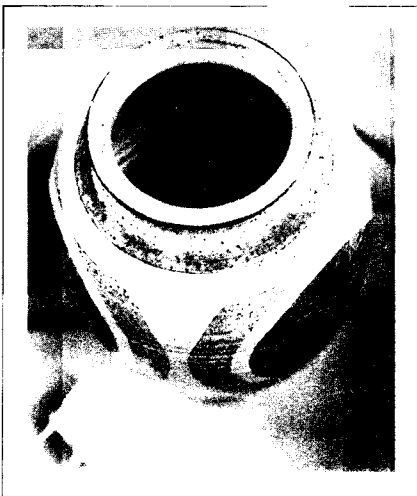

# LEARNING FROM MISTAKES

If you are disappointed with a piece of ware, look through this section to find out what caused the defect. This section covers the majority of problems you will encounter in ceramics.

## Bisque

**Warped ware** can be caused by distorting upon removal of the piece from the mold, firing too close to the elements, or firing a piece in an unnatural position. To prevent porcelain cups or bowls from warping when firing the greenware, edge the top of a cup with pinches of dry silica or *DRY* all purpose, high fire kiln wash and place a second cup on top of the first cup, lip to lip, with handles going in opposite directions. Porcelain greenware plates may require firing in plate saggars to prevent warping during firing.

**Sagging ware** is usually the result of overfiring. Porcelain objects can sag if not properly supported during firing.

## Glaze

**Crazing** is usually caused by underfired bisque. Bisque should be fired to the highest temperature at which it will still take glaze. Crazed ware may be refired to the proper cone. **CAUTION:** *China paints and other overglazes will burn off when fired to 06.*

**Glaze too thin in spots** can be caused by uneven glazing or a "hard spot" on the bisque. Ceramic glaze should be applied in flowing coats; first in one direction and the next coat in an opposite direction (horizontal, then vertical or vice-versa). Allow to dry between each coat. Some glazes may require twice the recommended coats, because of thin application. Porcelain glaze should be sprayed or a brush-on type used. "Hard spots" are sometimes the first spot where the poured slip touches the mold. Heating bisque in an oven to approximately 120° F. will help in applying glaze to hard bisque.

**Crazing immediately on removing** from the kiln can be caused by not firing the ware hot enough. Refire to the proper cone. Crazing in spots can be caused by not having mixed the glaze thoroughly before using.

**Black specks** in the ware are usually caused by organic materials not completely burned out in the bisque firing. This works its way to the surface during the glaze firing.

**Pinholes and bubbles** in glaze or glazed ware can be caused by too heavy a glaze application, by severe underfiring or by dust on the bisque. Damp bisque can reduce the number of air pockets and pinholes that may form when glaze dries too quickly. Clean bisque with tap water or use a base coat of glaze thinned 3 parts glaze to 1 part water immediately before applying glaze in the usual manner to the bisque.

**Poor color** in colored glazes can be caused by too thin an application, placing ware too close to an element or to other glazed ware which may be incompatible, insuf-

## REMINDERS

efficient venting during the early stages of firing or overfiring glazes in the red family.

**Light edges** on dark glass glaze pieces may be caused by the flow of the glaze away from the edges in two directions. Try an extra coat of glaze on the edges, or apply a thin coat of underglaze in the following manner: Mix 1 part water with 2 parts of suitable dark or black underglaze and brush a thin wash coat of the underglaze over the bisque ware. Then, immediately apply the first regular coat of full strength glaze. Allow to dry thoroughly between coats. Continue with number of coats recommended by the manufacturer.

**Sagging glaze** is usually caused by applying too much glaze on a vertical surface causing the glaze to actually sag when fired.

**Crawling or bare spots** on a fired piece can be caused by applying the glaze too heavily. Oil from your skin that gets on the greenware before it is fired can also cause this. Another cause may be hard spots from too much polishing of your greenware when sponging. A few drops of vinegar in your sponging water will help alleviate this problem. Crawling may be corrected by applying more glaze to these spots and refiring.

### Underglaze

**Streaks** in underglaze are usually caused by not applying enough coats to the greenware. After a piece has been decorated with underglaze and fired, you may check it for streaks by submerging it in water and immediately removing it. The piece will appear glossy, just as if it had been glazed, and streaks and thin spots will show up. The weak spots can be touched up and refired. Be sure the underglaze has been fired before putting it under water. For interesting designs, underglaze colors may be applied over unfired matte or texture glazes that do not flow.

### Overglaze

**Breaking** in overglaze firing can be caused by poorly fired bisque. A slow bisque fire is always better for ware that is to be china painted. The greenware should be completely dry *before* being placed in the kiln. Standing plates on edge or using a plate holder gives good heat circulation and will help prevent plate breakage.

**Purple spots in gold** are usually due to a thin application of gold or too much thinner. If gold is applied accidentally to an area it will show purple after being fired unless cleaned with a good gold remover.

**Broken lines** in gold can be caused by overfiring or too heavy an application. However, this is can be very attractive when gold is crackled over a dark color of fired glaze.

**Peeling china paint** can be caused by the paint being applied too heavily.

**Loss of color** in china painting is usually a result of overfiring or thinning your paint with too much medium when applying.

**Faded colors in overglaze decals** are a result of either underfiring or overfiring. If pinks and reds are drab, refire to a hotter cone. When used with a china paint background, apply and fire the decals first, then china paint and fire again. Check the recommendations

of decal supplier. If decal was underfired, refire to proper firing cone. If decal was overfired, the design may be repainted in china paints and refired.

**Weakening of luster colors** can be caused by overfiring.

**White spots** in lusters or metals can be caused by moisture on the ware before it was placed in the kiln or from having been fired at the same time as other overglazes. *Apply lusters only on a dry day.*

**Powdering of luster colors** can be caused by too heavy an application.

### Porcelain

**Bumps** in porcelain are usually caused by wet greenware and overfired porcelain bisque.

**Lack of translucency** in porcelain can be caused by the ware being poured too thick and underfired.

**Cracks** in porcelain bisque are often the result of a strain on the greenware while drying. *Do not force-dry greenware.* Cracks may be mended with one of the "magic menders" available from your supplier.

**Holes in lace or fabric** that appear after firing can be caused by inadequate application of the slip. Wash the fabric thoroughly before dipping it into the slip. Apply enough slip to the fabric so the clay will be strong enough to hold its own weight. The fabric must burn out before the clay matures, leaving only the clay shell, which must be strong enough to support its own weight.

## REMINDERS

1. Place your kiln on the stand provided—no substitute.
2. Before firing your kiln for the first time, check for bulging elements by performing the kitchen knife test.
3. Locate your kiln at least 12 inches away from any wall or combustible surface. Keep unsupervised children away.
4. Coat the tops of shelves and bottom of kiln with all purpose, high fire kiln wash.
5. Always place a large cone on a kiln shelf in every firing. Make sure you can see it through the peephole before placing a shelf over it.
6. Keep a firing log book. Write down cone number, type of ware, firing time and firing results.
7. Wear Paragon firing safety glasses to see the cones through the peepholes.
8. Check your circuit breakers or fuses *first* any time the kiln stops firing.
9. The Kiln Sitter and TouchnFire controller are no guarantee against overfiring. Check the kiln yourself at the expected shut-off time.
10. Some red or yellow glazes should be fired separately.
11. Use only tested, approved, and properly labeled glazes for food and drink containers.
12. Do not attach an extension cord to your kiln's power supply cord.
13. Do not exceed the maximum temperature on your kiln's name plate.



14. Do not allow kiln's power supply cord to touch side of kiln.
15. Do not touch hot sides of kiln or lid handle.
16. Allow kiln to cool to room temperature before opening lid.
17. Prevent glaze or kiln wash from touching elements. Both will burn out an element with the next firing.
18. **UNPLUG** kiln before touching heating elements with anything.
19. Do not use stilts with porcelain and stoneware.

# ELEMENT MAINTENANCE

## How to Get the Longest Life Out of Your Elements

The elements in your Paragon kiln should last for many years of normal use. With time, however, the elements gradually draw less and less power, and firings take longer and longer. Elements should be replaced when firing time becomes excessive.

High temperature elements are damaged by contact with silica or silica bearing compounds, such as glaze and kiln wash. If silica touches an element, the element will burn out during the next firing. This type of damage is not covered by warranty.

Also, reduction firing, which removes the oxygen from your kiln, will ruin your elements. The elements are protected by a coating of oxidation, which reduction firing destroys. Reduction is performed at your own risk; elements damaged by reduction are not covered by warranty.

All heating element wires change in length with use. This is an inherent characteristic that metallurgical science has never found a way to control. This change can cause elements to shrink away from the corners and bulge outside the grooves into the kiln. At porcelain temperatures, however, elements become quite soft and will not support their own weight. During high temperature firing, the elements soften to conform to the shape of their grooves.

If you never fire hotter than cone 05, the element never becomes soft enough to conform to the grooves, so bulging may occur. If you do not fire hotter than 05 and you are having a problem with bulging elements, you may want to pin the elements in place as follows:

1. Cut a Paragon element staple in half at an angle to leave a sharp point.
2. Bend about  $\frac{3}{16}$ " at a right angle.
3. Grasp the bent portion with pliers and push it through the lip of the groove at a slight angle. The pin must go over the bottom of the turn in the element coil, holding it against the bottom of the groove.

### Alternate Method

Push a straight piece of element staple wire, cut at an angle, over a turn of wire and into the back of the

Sectional View from End of Wall Brick

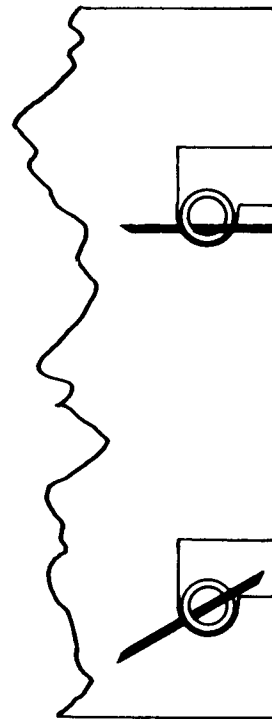

groove. This method does not fasten the element as securely as the above method. Its only advantage is neater appearance.

If you check to make sure the elements are seated when you set up your new kiln, and if you fire your kiln to cone 05 or hotter occasionally, your elements will probably stay in their grooves throughout their life. Should the elements start to bulge out of the grooves, they must be reseated immediately.

## Reseating a Bulging Element

Once an element has been fired, it becomes brittle and will break if it is bent while cold. Follow this procedure to heat element. **Always unplug kiln before touching element with anything!**

**S & SnF-series** Manually engage Kiln Sitter and turn switch(es) to HIGH position. (SnF-series, turn top switch to MAX. Put time in 2nd and 3rd switches. Turn 2nd and 3rd switches clockwise slowly until you hear a click. Elements are heating now.) Heat element until it glows dull red. Turn off switch(es), disengage Kiln Sitter and **UNPLUG** kiln.

**TnF-series** Program the kiln to heat at a rapid rate. When the elements glow dull red, touch **STOP (#)** and **UNPLUG** the kiln.

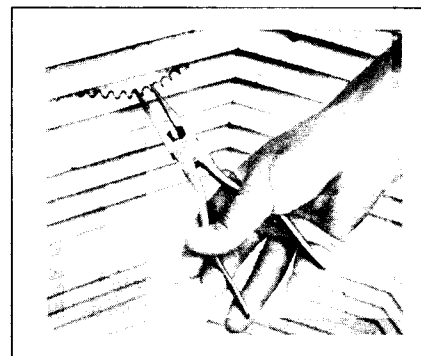

Shrinking a bulging element.

- 2 With a pair of long nosed pliers (dime store quality will work fine), shrink the bulging portion of the element by pressing the individual turns in the coils together

## ELEMENT MAINTENANCE

slightly. Take a little from each turn so that no two turns will be pressed tightly enough to touch.

**3** As the element shrinks, work it back toward the groove and into place. Work rapidly, and at the first sign of stiffness in the coils, stop bending and reheat the kiln. The elements do not have to be red to be bent safely, as the stiffening can be felt through the pliers.

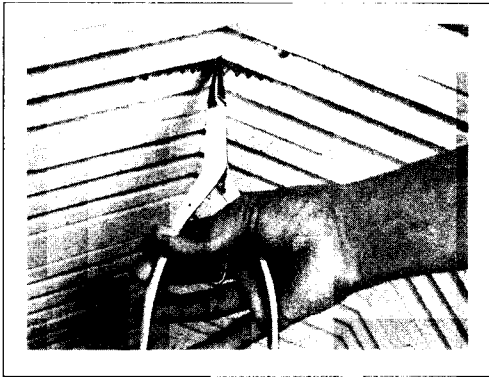

Expanding an element that has pulled out of a corner.

**4** To lengthen the element to fit into the corners, reverse the above procedure and expand the distance between coils by using snap-ring pliers. Use caution, as your warranty covers elements that fail only in service under normal use and not from being broken while cold.

**5** When you have the coils positioned above the dropped recess in the grooves, reheat the kiln, turn off the switch(es), **UNPLUG** the kiln, and run a blunt kitchen knife around the elements to seat them into grooves and to make sure they fit all the way back into each corner.

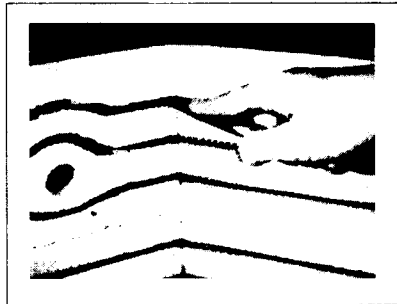

*It is important that the kiln is unplugged before you touch an element with a knife! Please double check.*

*Do not use a plastic object, such as a comb, to press hot elements into their grooves. Melted plastic ruins elements.*

**6** Fire the kiln to cone 4 or 5 to soften the elements completely.

### How to Test for a Burned Out Element

**Always UNPLUG kiln before removing switch box or touching elements.**

The center elements of most current Paragon kilns are cooler elements than the top and bottom elements. These cooler elements do not glow until the kiln has fired for some time. Also, many Paragon kilns have elements wired in series. Elements wired in series with a burned out element all stop firing. So you can't always tell which element is firing by turning the kiln on,

opening the lid and watching for elements that turn red. With an ohmmeter, however, you can find a burned out element in any Paragon kiln.

**1 UNPLUG** kiln. Remove screws holding switch box to kiln. Remove switch box.

**S and SnF-series owners:** *Pull switch box straight out to avoid damaging Kiln Sitter tube.*

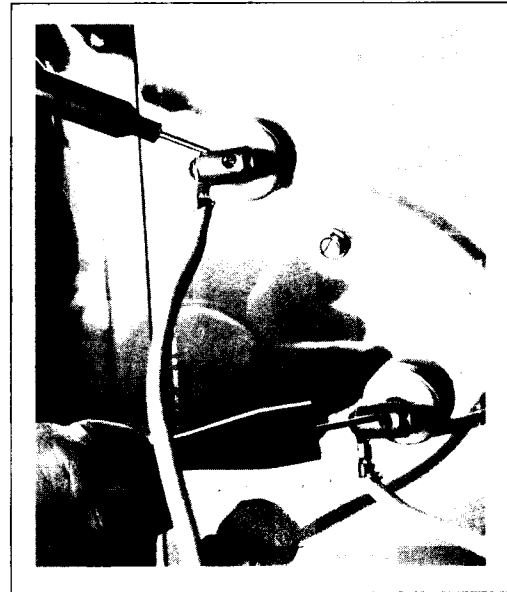

**2** Touch the ohmmeter leads to the two element connectors of each element. A no-needle-movement reading indicates a broken (burned out) element.

**3** If the element you are testing has two or more element lead wires attached to the same element connector, you must temporarily disconnect those wires. Hold element connector with pliers as you remove the screw. Be gentle to avoid breaking the element. (Elements are brittle after being fired.) Do not disturb the screw holding the element, only the one holding the lead wires. Reconnect the wires securely after testing the element.

### How to Replace an Element

No mechanical skill is necessary to install Paragon replacement elements. However, your local Paragon dealer will install the element for you at a reasonable charge. If you do not have a local dealer, see your appliance shop repairman. He is more experienced in servicing heating devices than an electrician.

Paragon replacement elements are formed to the shape of the kiln at the factory. However, a little stretching or compressing may be necessary for a perfect fit. It is safe to bend and stretch new elements before they have been fired, but once fired and allowed to cool, elements become brittle and will break if bent.

**1 UNPLUG** or disconnect the kiln and allow to cool to room temperature.

**2** Remove screws on each side of switch box and let box hang by element lead wires.

**S & SnF-series kilns:** *Pull box straight out to avoid damaging Kiln Sitter tube.*

**3** Remove the screws in the element connectors that hold the element lead wires to the element you are replacing.

**4** On the same connectors, loosen the screws that hold the element and throw old connectors away. Always use the new connectors furnished with the new element.

**5** Remove and save the porcelain insulators that were behind element connectors.

**6** Remove the old element carefully to prevent breaking the lip of the element grooves.



If the old element burned out due to contact with foreign materials, there will probably be a melted, glazed spot in the element groove. Glazed spots left in the grooves may ruin the new element, so dig out any of these spots. The small hole left in the groove will not affect the new element. Small pieces of firebrick in the grooves should be removed with a dry brush (such as a household paint brush) or vacuum cleaner.

**7** Protect the new element from accidentally coming in contact with kiln wash by placing newspaper on the kiln bottom. To keep from tangling up the element, keep it on the top rim of the kiln's sidewall when you feed it into the grooves. (If you place element in bottom of kiln, element will tangle up.) Also, arrange element so you're feeding the bottom loop first instead of the top one.

**8** Thread the new element into the upper element hole. To guide the element through, you can look into the hole where the porcelain insulator goes. (Don't let the element hit your eye!) Or you can use the twisted end of the old element to thread the new element into the holes. To do this, insert the end of the old element into the hole



where the porcelain insulator fits until the element appears in the firing chamber. Press the end of the new element against the end of the old one and push new element all the way through.

**9** The element is bent slightly where it fits into each firebrick corner. The bend must fit all the way into the back of each corner. As you feed the element, hold it with both hands in such a way that you are applying a constant pressure that pushes the element into the

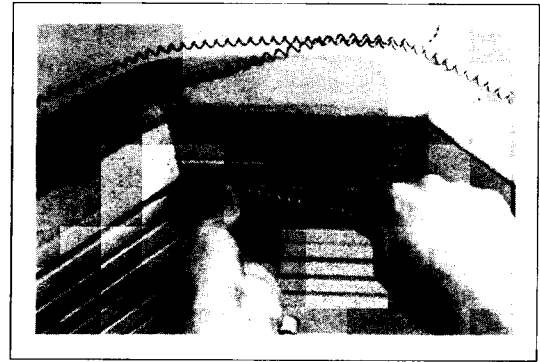

corners. If you let go before the element is completely threaded, it will spring back out of the corners.

After the first element bend is in its corner, do the next corner. If the next element bend will not reach the next corner, gently stretch that section of element with your hands to make the next bend reach its corner. If

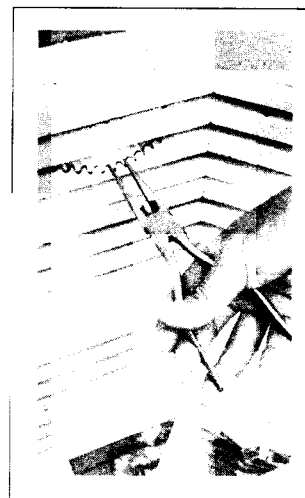

the element is too long between bends, let that section of element curve out of the groove. Then continue threading the element into the other corners. When element is completely installed, go back to the section that was too long. Compress coils with long-nose pliers until the element fits into its groove. No two coils should be compressed tightly enough to touch.

**Remember, if you do not push the element fully to the back side of each corner, the element will not stay in**

**the grooves when fired!**

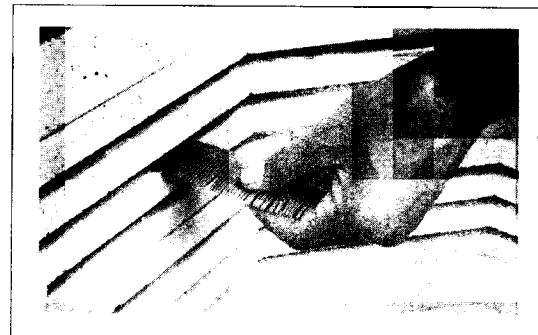

**10** Press element down into the lower part of the groove with a plastic comb or wooden tongue depressor.

**11** Reinstall the porcelain insulators. Push them flush against the heat shield. They protect element from contact with case and heat shield, so they *must not* work their way out after the element connector is tightened into place.

**12** Sandpaper the eyelet of the element lead wires until bright and clean of all oxidation. (Install new lead wires if insulation on old ones is brittle.) Use the brass screw

## FIREBRICK MAINTENANCE

to connect lead wire eyelets to the new element connectors. Before tightening screw, adjust eyelet to where it will be tilted away from heat shield when connector is attached to element. Then hold connector with locking pliers and tighten brass screw securely with a 1/4" nutdriver.

**13** Pull end of element tight and install new element connectors snugly against porcelain insulators to prevent insulators from slipping away from brick wall.

Use stainless screw in the element connector to hold the element. (The brass screw holds the lead wire eyelet.) Hold connector with locking pliers as you tighten the screw with the 1/4" nutdriver. Tighten the screw to 30 inch pounds (about 1 1/4 turns past the point of resistance).

**14** Cut off twisted end of element even with side of element connectors. Leaving the excess element sticking out past element connector could ruin your new element! (The element could short against something in the switch box.)



**15** As you move the switch box back into place, check to see that no wire touches an element connector. Wires and wire nuts must also not touch kiln's case inside the switch box. **Wires and wire nuts will burn if they touch the case or element connectors.** Reinstall screws in switch box and tighten.

# FIREBRICK MAINTENANCE

## Patching a Lid

Do not fill chipped areas of the lid's inner surface with repair cement. This is because expansion of cement differs from that of the brick, so the cement will break out when fired. Instead, coat chipped areas with thinned Paragon Kiln Coating and Repair Cement. (See instructions on bag.)

When large sections of the lid are cracked, the lid is seldom worth repairing. This is because a heavily cracked lid crumbles when separated at the cracks for repair. However, you can continue using a cracked lid. Before each firing, vacuum the dust from the inner lid surface. Replace the lid when it becomes so cracked that dust is unavoidable. Or use that kiln to fire only greenware.

You can replace damaged sections of the lid, such as the section near the hinge, with fresh firebricks. Saw off the damaged section clean through the lid with one straight cut. Then cement a new brick section into place. The cement seam should be no thicker than 1/16". (Look at a new lid or bottom as an example.) Anything thicker tends to break. This is why we recommend cementing only single, straight cuts. It is much more difficult to obtain a tight fit on multi-sided cuts, such as a square.

**1** Remove lid from kiln. (See lid removal instructions on the next page.) Remove lid band by first removing all screws from it and then loosening band.

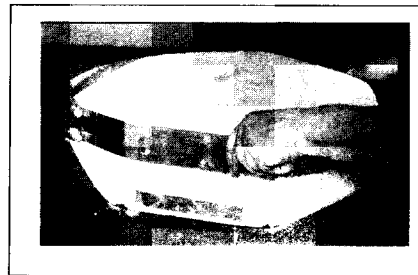

**2** Trace damaged section of lid onto a piece of paper. Cut the paper along the traced line with scissors.

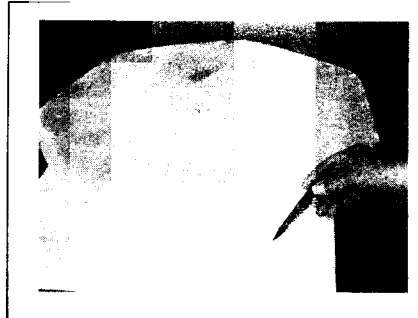

**3** Saw off damaged section of brick in one straight line. Use a band saw or hack saw. Smooth with sandpaper. Cement together a new brick section and let dry overnight. Then match the new section to the lid by sliding them together back and forth on a flat surface. Sanding also helps. Both surfaces must match perfectly. Remove all dust with a vacuum or soft brush.

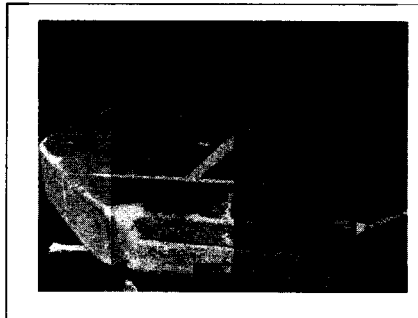

**4** Apply repair cement liberally to one of the two brick surfaces. Press surfaces together quickly. Then slide back and forth to work cement into the brick pores and to work out ex-

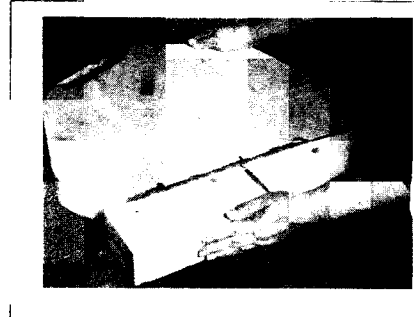

cess cement. Stop when you feel resistance. Do not disturb the bond until it has dried. Scrape off excess cement.

**5** Let dry overnight. Cut out the brick section using the paper tracing you made in step 2. Then sand away excess cement from lid surface.

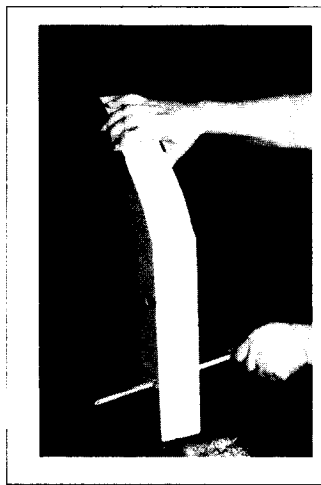

**6** Use a hacksaw to make a groove in the new lid section for lid retainer (if necessary). Reinstall lid band.



**7** Clean off all dust from the lid and apply a very thin wash coat of cement. With a soft cloth, immediately remove all of the cement coating possible.

After the kiln is fired, it may seem that the thin wash coat has disappeared. However, you have actually left the inside surface of the lid with a hard, dust-proof coating.

### Replacing a Standard Lid (No LiteLid)

These instructions are for kilns not equipped with the LiteLid spring counter-balance.

*Note: Drill holes with a 1/8" bit. Tap a mark in the metal with a center punch or nail to start holes. Do not over-tighten screws. Stop turning when the screw feels snug. Wear safety glasses when drilling.*

**1** Remove the nut that holds the lock-in lid support to the lid. (If your kiln is equipped with chains instead of a lid support, remove chains from lid.)

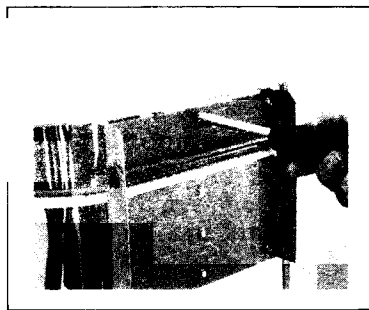

**2** Remove the screws from the upper lid hinge. (Do not remove the lower hinge section from the kiln case. Leave hinge rod in place.)

Lift the old lid off the kiln.

**3** Gently place the new lid onto the kiln. Line up the edges of the lid with the sides of the kiln.

**4** The hinge contains play to allow the lid to float at high temperature. This adjusts for heat expansion. Lift the upper hinge half up and down, and you will feel this play. The upper hinge must be in the lower part of this play when you attach the hinge to the lid. Mark holes in the lid with a felt-tipped pen. Drill holes. Install screws.

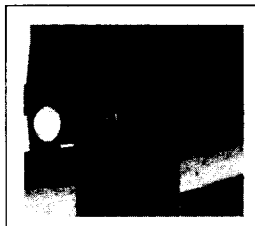

The lower hinge half uses an oval hole to allow for heat expansion.

**5** Lift up the back of the lid. The lid should have play in it. If there is no play, the front of the lid could tilt upward during firing.

**6** Install the upper lock-in lid support stud. Align it as in the photo at right. Fasten the lid support to upper stud with the nut removed earlier. (Install chains if kiln is equipped with chains.)

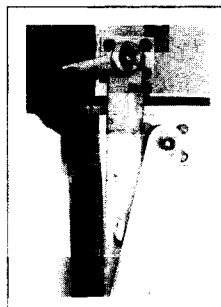

**7** Install the lid handle and Prop-R-Vent latch.



### Replacing a Lid on Kilns Equipped With the LiteLid

These instructions are for 10 and 12-sided kilns equipped with the LiteLid spring counter-balance.

*Note: Drill holes with a 1/8" bit. Tap a mark in the metal with a center punch or nail to start holes. Do not over-tighten screws. Stop turning when the screw feels snug. Wear safety glasses when drilling.*

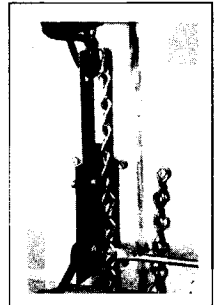

**1** Raise the lid. Have someone hold the lid in its upright position while you remove the two bolts that secure the bottom spring loop. With the spring pressure released, close the lid.

**2** Remove all screws fastening the front and rear LiteLid brackets to the lid. Lift the LiteLid up and out of the way.

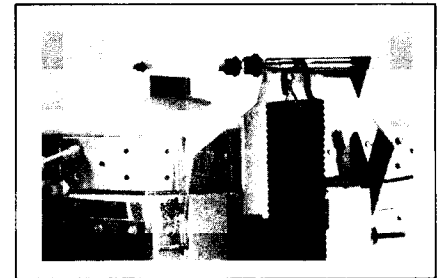

Removing the rear lid brackets.

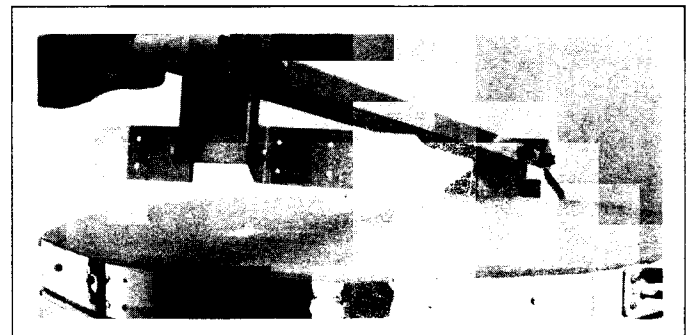

**3** Lift off the old lid. Gently place the new lid onto the kiln. Line up the edges of the lid with the sides of the kiln.

**4** Lower the LiteLid onto the lid, using cardboard to protect the lid from scratches.

**5** Center the LiteLid front lid brackets horizontally between the kiln wall brick seams and vertically between the upper and lower edges of the lid. Hold the bracket in this position while you mark two holes for each bracket

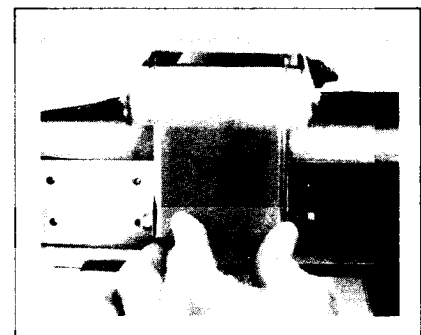

## FIREBRICK MAINTENANCE

with a felt-tipped pen. Move the brackets out of the way. Drill holes. Screw the brackets onto the lid. Then drill the other holes and install screws.

**6** The LiteLid hinge has play in it to allow the lid to float at high temperatures. This adjusts for heat expansion. Lift a rear lid bracket to feel this play. The lid bracket must be in the lower part of this play when you attach it to the back of the lid.

In addition, there should be a  $\frac{1}{16}$ " gap between the back of the lid and the kiln wall. This is to insure sufficient room for expansion. Place several sheets of paper with a total thickness of about  $\frac{1}{16}$ " under the lid at the hinge area. Then mark two holes on the lid with a felt-tipped pen for each bracket. Drill holes and install two screws in each bracket. Then drill holes and install the rest of the screws.

**7** Install the lid handles and Prop-R-Vent latch on the new lid.

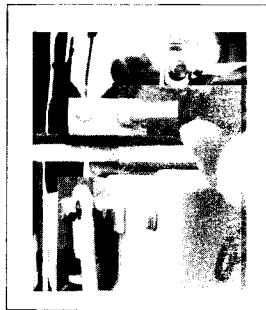
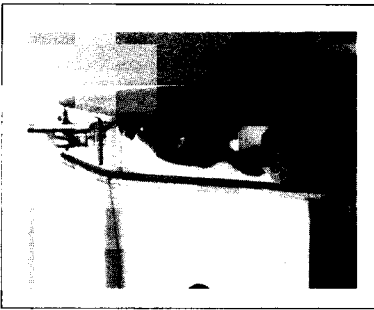

**8** Have someone hold the lid in the open position while you attach the lower spring loop using the two nuts and bolts removed in Step 1.

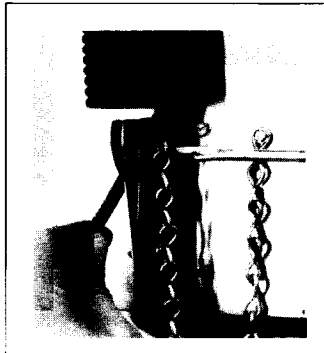
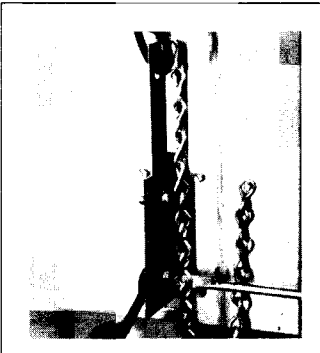

10 sided kilns use a spacer for the lower spring loop.

12 sided kilns: the opening in the spring loop should face outward.

## Brick Bottom Maintenance

Keep the bottom covered with high fire kiln wash at all times. This prevents glaze drippings from embedding into the brick. When glaze drips onto the bottom, scrape it off and apply kiln wash to the bare spots.

If the bottom of your kiln becomes slightly uneven, scrape off the old kiln wash and apply a new coat. Should the brick become unusually rough, you can patch it by thinning repair cement to the consistency of coffee cream and then mixing with coarse grog made from crushed insulating firebrick. When fired, this will leave a durable surface. Do not use repair cement without grog for filling large holes; it will crack and pull out, and since it is not an insulator, will create hot spots.

You can also turn the bottom over for a fresh, smooth surface.

**1** Remove the lid by first removing the rod that runs through the hinge. The rod is held in place on each end with a spring lock. Grasp the spring lock with pliers and pull off with a twisting motion. Pull out hinge rod, then remove the lock nut on lid support. (Your kiln may have support chains instead of lid support.)

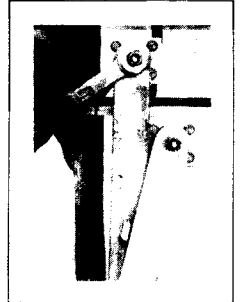
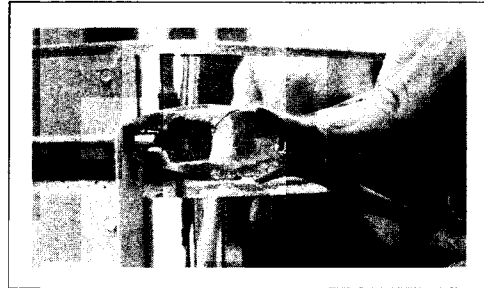

**2** Vacuum the firing chamber. Carefully turn the kiln upside down onto a piece of cardboard or similar padded surface. Mark the steel base near the seam of the steel jacket.

**3** Remove only the screws at the bottom of the kiln jacket. Pry off the full-formed steel base with a screw driver.

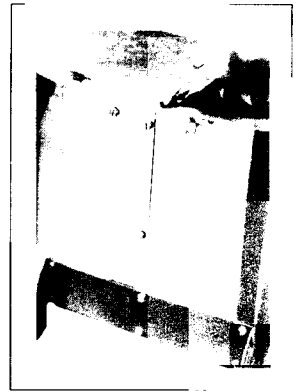

**4** Take brick bottom out and turn it over.

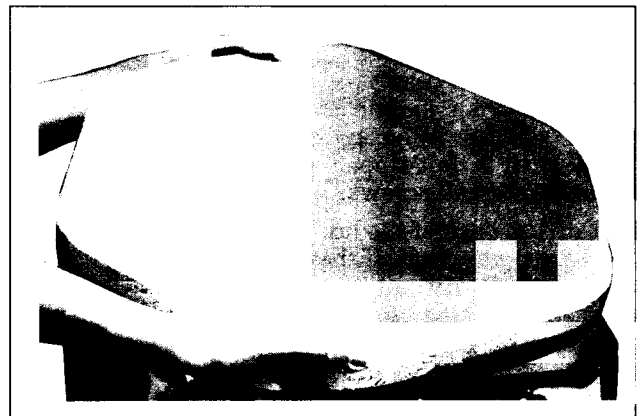



**5** Reinstall the steel base. Place the mark against jacket seam to line up screw holes. Reinstall screws and place kiln in an upright position. Reinstall the lid. Vacuum the inside of kiln, especially the firebrick grooves.

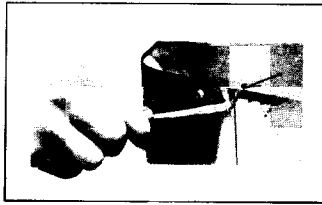

**Sidewall Maintenance**

The insulating refractory brick in your kiln walls is extremely fragile and chips easily. Please load and unload your kiln carefully.

**Glaze Spots and Chips**

If glaze drips onto the kiln walls during firing, repair it at once. Otherwise the glaze will remelt each time the kiln is fired. If it spreads into an element groove, it could cause an element to burn out. Carefully dig all the glaze out of the brick with a screwdriver or knife. The small hole that remains will not harm your kiln and can be left unrepaired.

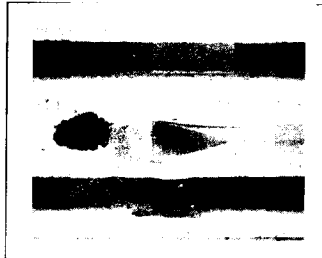

Do not be concerned with chipped sidewall firebricks. There is no need to try to repair them.

Do not be concerned with chipped sidewall firebricks. There is no need to try to repair them.

**Pinning an Element to a Damaged Firebrick**

When a sidewall brick breaks, it is usually the element groove that comes off. This will not affect your kiln's operation unless strands of element that could expand and touch each other are left exposed. The easiest way to repair that type of damage is to pin the elements to the firebrick with element staples.

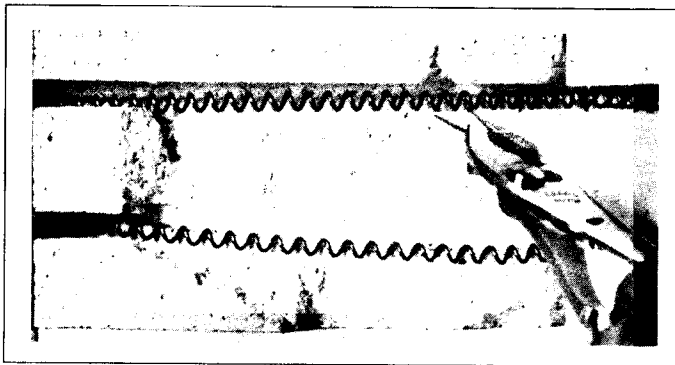

**Replacing a Sidewall Firebrick**

Broken sections of wallbrick are rarely serious enough to warrant brick replacement. Avoid replacing firebrick if at all possible.

In replacing wallbricks, you risk breaking an element. So wait until the element needs replacing to replace firebrick. Do not attempt to replace terminal bricks (the ones located behind the switch box) unless you are rebuilding the entire kiln.

**1** **UNPLUG** kiln. Remove the lid by removing screws from bottom of hinge. Remove lock-in lid support or support chains. Lift the lid off the kiln. (LiteLid owners:

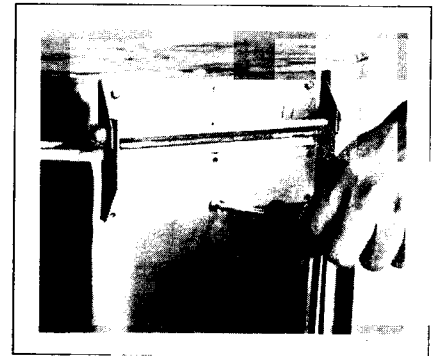
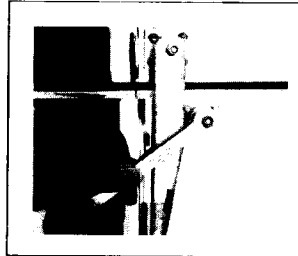

release bottom spring loop, pg.30. Remove all screws from sidewall brace.)

**2** Remove the screws that fasten the case together. Peel back the case far enough to gain access to the brick you're replacing.

**3** Gently lift element up from bottom of element grooves of the brick you're replacing. Use the tip of a pencil to lift element. The element should be above the lip of the recessed groove so that it will remain undamaged when you push the brick out. The element is brittle and breaks very easily.

**4** Reach inside firing

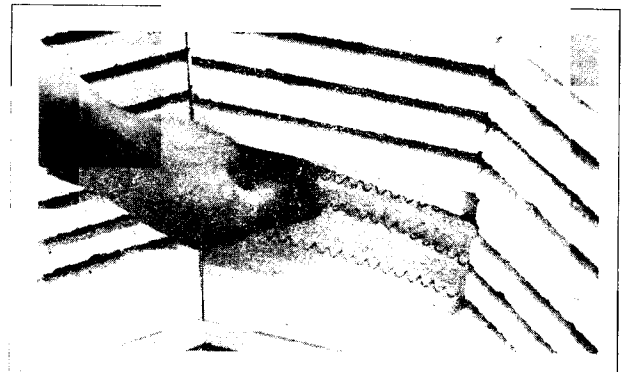

chamber and push the damaged firebrick outward. Do not touch element.

**5** Remove the firebrick by pulling from the outside of the firing chamber. The firebricks above the one you're removing will probably be loose. Have someone hold them in place while you remove the damaged brick.



## S & SnF SERIES SWITCH REPLACEMENT

**6** Insert new firebrick into place. Sand the ends if necessary for a good fit.

**7** Reinstall the case. The easiest way to bring the case ends together is with the Paragon case tightener. (Call your Paragon dealer to order one.) Tap the case on the flat areas all around the kiln with your open hand. This will help draw the case together. Reinstall case screws when the screw holes line up.

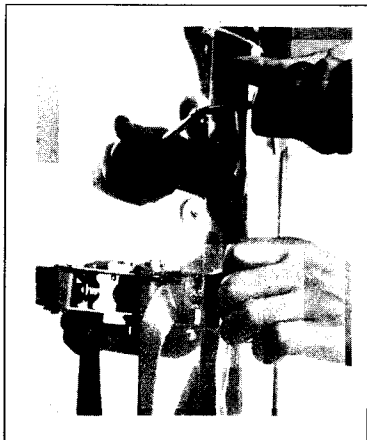

**8** Reinstall lid hinge and lock-in lid support (or support chains). For LiteLid: reattach sidewall brace & spring.

**9** Use the pencil to gently lower element into the recessed grooves of the new brick. The element will slide right into place almost by itself.

# S & SnF SERIES SWITCH REPLACEMENT

### Switch Diagnostics

Look at your wiring diagram to see which elements are controlled by each switch. (We will mail you another wiring diagram if yours is lost.) If the elements to a particular switch are not firing, check those elements and the wiring to the switch. (See page 27, "How to Test for a Burned Out Element," for instructions on checking elements.) If the switch powers a relay, check the relay using instructions on page 34 - 35.

If wiring, relay (if any) and elements are good, replace the switch.

*Note: If push-on terminals do not have a snug fit, gently squeeze the end of the terminal with pliers.*

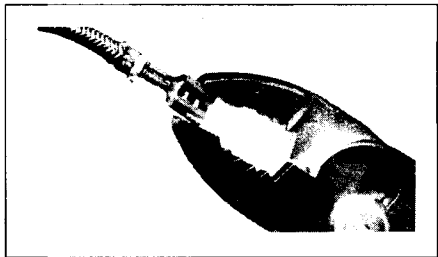

**1** Pull off switch knob with fingertips. Some switch knobs are held in place by a set screw on the side of the knob. If knob won't come off when you pull it, check to see if a set screw is securing it to the shaft.

**2** UNPLUG the kiln. Remove and save the screws at the side of the switch box that hold it to the kiln and let the switch box hang by the switch-to-element lead wires.

*When removing switch box, pull straight out to avoid damaging Kiln Sitter tube.*

**3** Hold the new switch at the side of the switch box in the same position as the defective switch. Remove and transfer one wire at a time from the old switch to the new one making sure each connection is tight.

**4** Remove the single nut from the front of the defective switch. (Some switches are fastened to the front of switch box with two screws. Remove screws.) Remove switch and put new one in place making sure it is right side up.

Reinstall shaft nut checking to make sure it is not backwards. Tighten so switch will not turn during operation. If switch is held in place with two screws, reinstall screws.

**5** As the switch box is moved back into place, check to see that no wires are touching kiln case or the element connectors. *Wires touching case or element connectors will burn.* Tighten switch box screws. Insert knob on switch shaft.

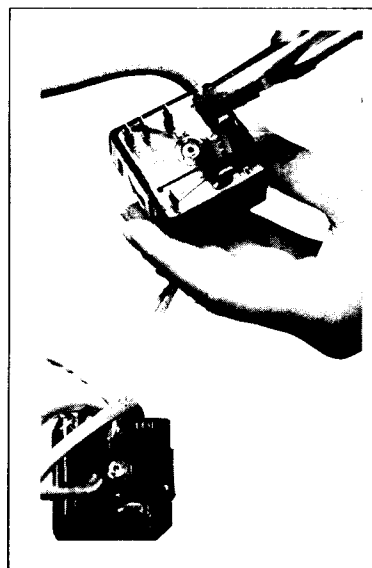

# TnF-SERIES ELECTRICAL MAINTENANCE

### TnF-Series Diagnostics

**SWITCH BOX WARNING: Do not remove switch box without first unplugging kiln.** *Touching a live connection inside switch box could be fatal. Do not attempt to check components inside switch box with a voltmeter. Kiln must be unplugged anytime switch box is removed from kiln.*

**CONTROLLER BOARD WARNING: When checking controller board with a voltmeter, remove only controller faceplate and not the kiln switch box.** *Before removing controller board, unplug the kiln. Then let the controller board hang on the switch box with the back of the board facing you. Plug the kiln back in before testing the board. The reason for unplugging the kiln when you remove the controller board is that some electronic components will be destroyed if they touch a grounded object with the kiln plugged in.*

Refer to Trouble-Shooting, page 4 in the electrical section, for further diagnostics.

## Wire Connections on Back of Controller

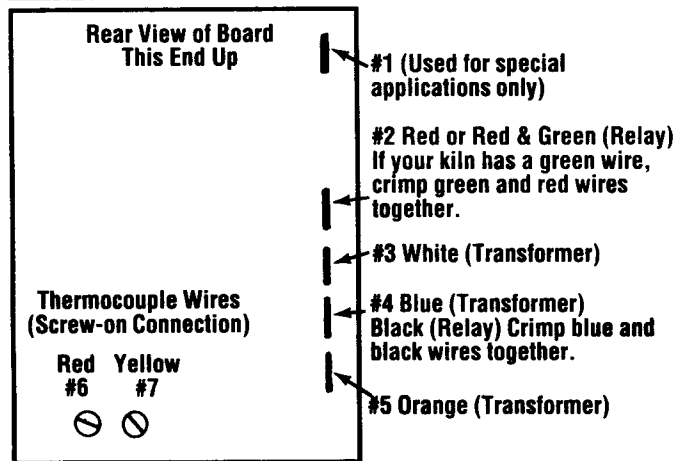

### PROBLEM:

#### Controller Display Does Not Turn On

##### Probable Causes:

- Tripped Circuit Breaker or Blown Fuse; Kiln Unplugged
- Blown Kiln Switch Box Fuse
- Defective Transformer
- Defective Controller Board
- Disconnected Switch Box Wire

Check the circuit breaker or fuse for the wall outlet. Then remove kiln's fuse and check it by placing the probes of an ohmmeter on the ends of the fuse. If the ohmmeter reading is 0 ohms, the fuse is okay. If the reading is infinity or no needle movement, the fuse is bad. Replacement fuse:

**AGC 1/2 A 250V AC**

If switch box fuses keep blowing, replace the kiln's transformer.

If the fuse was okay, check the controller board with a voltmeter. Make sure the kiln is unplugged, and remove the 4 screws holding the controller board faceplate to the switch box. Lift faceplate out of box and let the board hang on the box with the back of the board facing you. Plug the kiln back in. Touch voltmeter probes (in AC mode) to connectors 3 and 5. (This

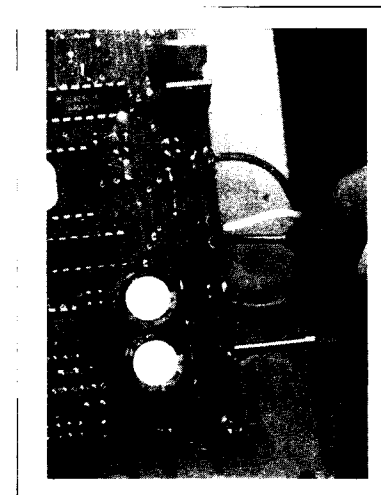
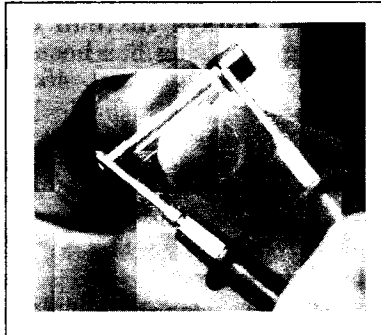

should be the white and orange wires.)

*Make sure the voltmeter is in the AC mode when placing the probes on connectors 3 and 5.*

If you find voltage (approximately 20 - 24 volts AC), current is reaching the board from the transformer, so the board is probably defective. No voltage means the transformer is probably defective. But before replacing the transformer, *UNPLUG* kiln, remove switch box, and look for a disconnected wire between the cord set and transformer and between the transformer and controller board.

### PROBLEM:

#### Controller Display Lights Up Normally, Some or All Heating Elements Do Not Fire

##### Probable Causes:

- Burned Out Elements
- Defective Controller Board
- Defective Relay(s)
- Disconnected Wire in Switch Box

First check the controller board with a voltmeter. Unplug the kiln and remove the 4 screws holding the controller board faceplate to the switch box. Lift faceplate out of box. Let the board hang on the outside of the box with the back of the board facing you. Then plug the kiln back in. Program the controller to fire at fast rate in Cone-Fire or 9999° F. rate in Ramp-Hold.

Put the voltmeter in DC mode. (It *must* be in DC mode.) Touch probes to connectors 2 and 4 for at least 12 seconds. If the meter reads 12 - 14 volts, the board is sending correct voltage to the relays, so the board is okay. Less than 12 volts at 2 and 4 means a weak transformer. No voltage at 2 and 4 means a defective controller board.

If the controller board checks out okay, *UNPLUG* kiln and remove switch box. Look for loose or disconnected board-to-relay, relay-to-element, and cordset-to-relay wires.

If you still haven't found the problem, check elements with an ohmmeter following the instructions on page 27. If the elements and wiring check out okay, the problem is most likely a relay.

*When a relay makes a chattering noise, the problem may be a weak transformer. A chattering relay can cause erratic temperature readings.*

**How to Test a Relay:** You will need an ohmmeter, 12 volt battery and 2 clip wires. (See photo and diagrams, next page.)

**WARNING:** You must disconnect the controller board-to-relay wires to test the relay(s) with a battery. Leaving the wires connected could damage the controller board.

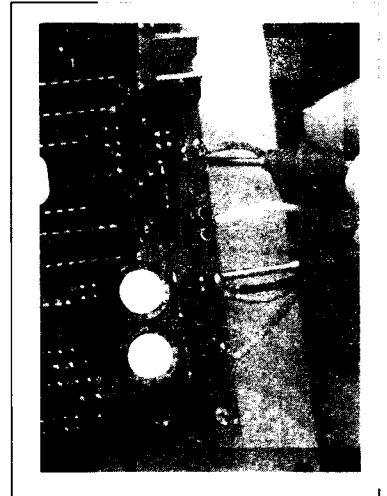

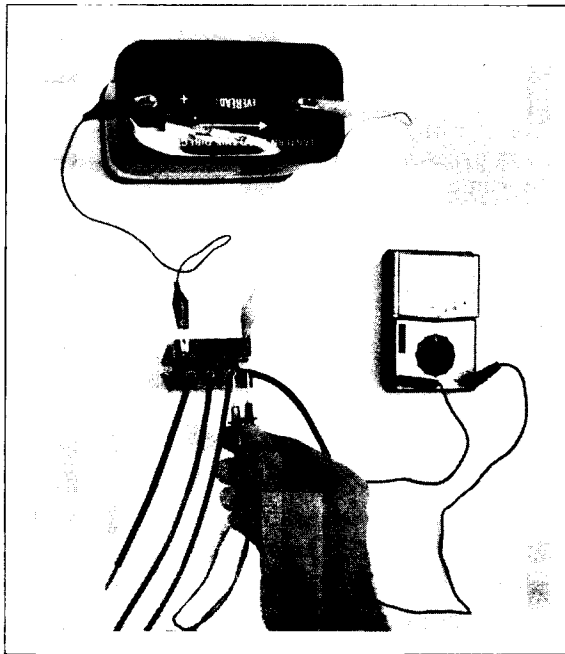

Testing a relay with a 12 volt lantern battery, ohmmeter, and clip wires.

**Relay Conversion Chart**

**Wiring for Omron & Aromat Relays**

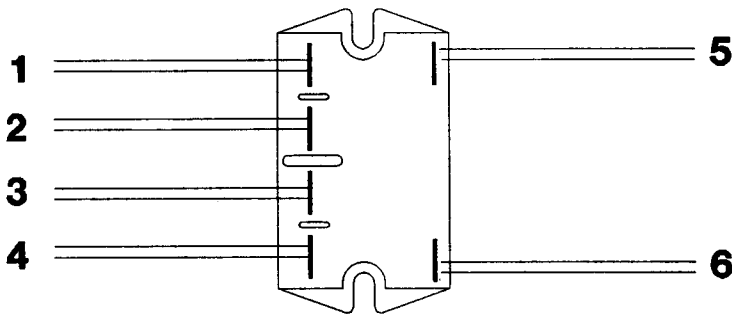

**Wiring for P & B Relay**

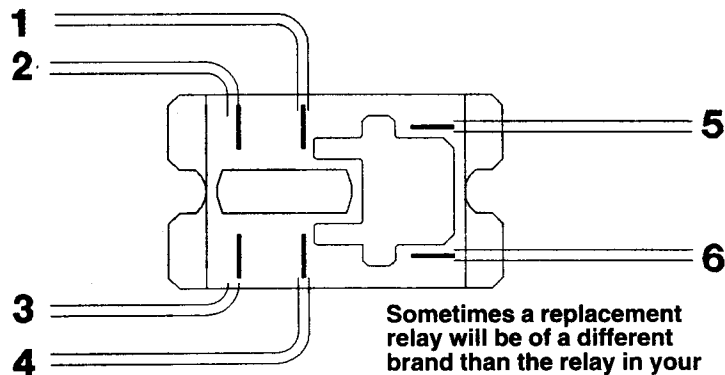

Sometimes a replacement relay will be of a different brand than the relay in your kiln. If so, transfer the wires from the old relay to the new one by the numbers on this chart. Ignore the terminal numbers printed on the relay bodies when using this chart.

**1 UNPLUG** kiln and remove switch box. Find the two wires going from the controller board to the relay you are testing. Disconnect these wires from the relay. Then connect a 12 volt lantern battery to the same relay terminals (#5 and #6 on diagrams, left column) using clip wires. You should hear a clicking noise when you make the connection. If there is no click, the relay is defective. (Make sure your battery is good before you assume the relay is bad.)

**2** Touch ohmmeter lead wires to relay terminals marked #1 and #2 in the diagram. With the battery still connected, you should get a continuity reading (0 ohms) on the ohmmeter. If you get a no-needle movement when the battery is connected, replace the relay. Place the ohmmeter wires on relay terminals marked 3 and 4 on the diagram and test the same way.

**PROBLEM:**

**Firing Interrupted by a PF or ErrP Message**

**Probable Causes:**

- Temporary Power Failure
- Low Wall Receptacle Voltage
- Corroded Cord Plug or Wall Receptacle
- Defective Transformer

**PF flashes alternating with the temperature during firing:** this means the power went off for a moment during firing. Then firing resumed. To go back to a normal temperature display, press **ENTER**.

**ErrP displays instead of firing temperature:** this means a firing has been interrupted by a longer power failure of about 30 - 45 minutes.

Low voltage can also cause the kiln to shut off and display either **PF** or a blank display. If this happens and you did not have a power failure, have the power company or an electrician check the wall receptacle for low voltage. Sometimes there is just enough voltage to program the board. But when the relays turn on, the voltage from the transformer is drained below the minimum operating level, and the display goes blank.

A corroded kiln cord plug or wall receptacle can cause a **PF** or blank display. Pull the plug from the wall and slide it back in several times to remove the corrosion. A loose wall receptacle screw or loose circuit breaker screw can also cause a power failure display.

See "Controller Display Does Not Turn On," page 34.

**PROBLEM:**

**Fail Message**

**Probable Causes:**

- Defective Thermocouple
- Disconnected Thermocouple Lead Wires
- Defective Board

**UNPLUG** kiln. Remove the 4 screws holding the controller board faceplate to the switch box. Lift faceplate out of box. Look at the back of the board. You should see a yellow wire and a red wire connected to connectors 6 and 7 near the bottom of the board. (See diagram, page 34.) If one of these wires is disconnected or loose, reconnect or tighten. (Grasp connector block to prevent block from twisting.) The controller should

work now. If the wires were attached securely to their connectors, perform this test:

**1** Remove thermocouple wires from connectors 6 & 7.

**2** Cut a paperclip in half. Insert a u-shaped paperclip piece between connectors 6 & 7. Tighten screws.

**3** Place the faceplate back into the switch box with two screws.

**4** Plug in the kiln. If the board reads room temperature, replace the thermocouple. If it reads **FAiL**, replace the board.



*The thermocouple and thermocouple lead wires are sold as a single unit. Therefore, damaged thermocouple lead wires call for replacement of the thermocouple itself.*

## PROBLEM:

### Err 0 Message

#### Probable Causes:

- *Electrical Spike, Arcing on Relay, Lightning*

When **Err 0** displays, press any key. The display will go back to **IdLE**. Check your program to make sure it wasn't cleared from memory. Then fire your kiln again.

## PROBLEM:

### Err 1 Message

#### Cause:

- *Temperature Rise Slower Than 12° F. Per Hour*

**Err 1** appears when temperature rise is slower than 12° F. or 12° C. per hour in Cone-Fire. When **Err 1** appears, the heating elements will shut off.

A kiln that fires this slowly may need new elements, voltage may be low, or you may be trying to fire hotter than the kiln was designed for.

When **Err 1** displays, press any key. The display will show the last temperature the kiln reached and hours fired before it shut off. Then it will go back to **IdLE**.

## PROBLEM:

### Err 6 Message

#### Cause:

- *Thermocouple Leads Hooked Up Backwards*

Unplug the kiln and remove the controller from the switch box. If the yellow and red wires are attached to the incorrect terminals at the bottom of the board (see controller diagram, page 34), reverse the wires. Reinstall the controller.

## PROBLEM:

### Err 8 Message

#### Causes:

- *Burned out element, Defective relay*

**Err 8** appears when the temperature drops for 18 seconds during the last phase of firing in Cone-Fire. Temperature drop could be caused by a burned-out element or loss of power to the elements. When **Err8** displays, press 1. The display will show the last

temperature the kiln reached and the hours fired before the kiln shut off. Then it will go back to **IdLE**.

## PROBLEM:

### Erratic Temperature Readings

#### Causes:

- *Thermocouple Lead Wires on Wrong Terminals*
- *Thermocouple Lead Wires Too Close to Other Wires*
- *Thermocouple Lead Wires Touch at Bare Ends*
- *Electrical Noise*

Even though protected by insulation, the thermocouple wires are sensitive to electromagnetic waves. Position them away from other wires inside the switch box. Thermocouple wires must be attached to the correct terminals. Check that the thermocouple wire ends are separated where the insulation has been stripped. Electrical "noise" can cause erratic readings. A chattering relay or arc welding machines operating nearby can cause electrical "noise" and erratic readings.

## Replacing TnF Switch Box Components

### Important when Replacing Components:

If a push-on terminal is loose, gently squeeze with pliers. Connections must be tight!

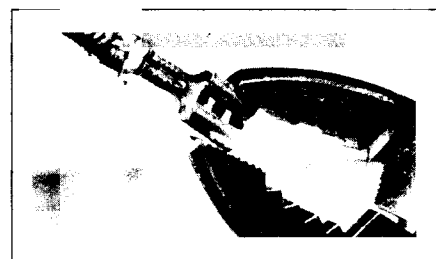

### Replacing Circuit Board Fuse

The fuse holder is located near the bottom of the switch box. Remove fuse by pressing in on the fuse holder and turning counter-clockwise half a turn.

Replacement fuse:

**AGC 1/2 A 250V AC**

**WARNING:** Replacing the fuse with one of a higher amperage will void your warranty.

### Thermocouple Replacement

- 1** **UNPLUG** kiln.
- 2** Remove screws on the sides of the switch box that hold it to the kiln, and let switch box hang by element-to-relay lead wires.
- 3** To prevent the thermocouple from touching anything metallic, it is held in place with a porcelain insulator. Remove the screw from the thermocouple fastener, which holds the



porcelain insulator in place. Pull thermocouple from its firebrick hole.

**4** Insert the new thermocouple into the firebrick hole so that it protrudes into the firing chamber by at least 3/4". Place a mark on the thermocouple 1" past the outside firebrick wall surface.

**5** Remove the thermocouple. Slide the porcelain insulator, wide end first, onto the thermocouple as far as it will go. Gently bend the thermocouple at the mark with your hands. Do not use pliers, or the thermocouple may kink.

**6** Slide the thermocouple back into the hole. Position the thermocouple fastener so that it holds the porcelain insulator against the heat shield. Install the screw.

**7** Position the thermocouple lead wires so they are away from the hot sides of the kiln case and electrical wiring. (Thermocouple wires next to or looped around other wires could cause erratic controller readings.) Do not allow the thermocouple to touch anything metallic, such as the heat shield.

**8** Check to see that no wires are touching the kiln case or the element connectors. **Wires touching element connectors or kiln case will burn out.** Install switch box.

### Controller Board Replacement

**1** UNPLUG kiln.

**2** Remove the 4 corner screws holding the controller faceplate to the switch box. Carefully lift out faceplate.

**3** Disconnect all wires from the back of the board.

**4** Connect the wires to the new board following the diagram on page 34. Reinstall faceplate.

### Transformer Replacement

**1** UNPLUG kiln.

**2** Remove the screws that hold the switch box to the kiln, and let switch box hang by element-to-relay lead wires.

**3** The transformer is located near the relay(s). Remove and transfer one wire at a time from the old transformer to the new one. Make sure each connection is tight.

**4** Unbolt transformer from switch box. Examine new transformer to make sure the primary is properly wired for your kiln's voltage.

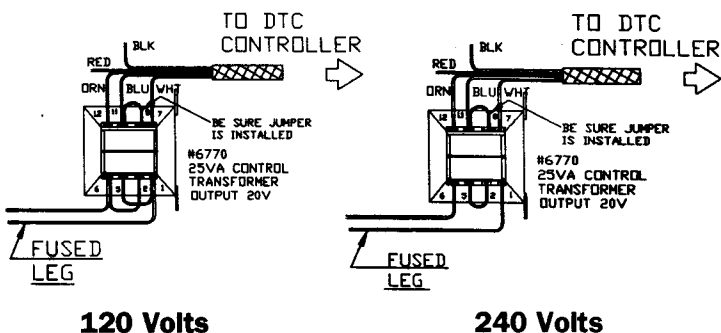

**5** Bolt new transformer into switch box.

**6** Check to see that wires are not touching kiln case or the element connectors. **Wires touching element connectors or the kiln case will burn out.** Move switch box into place and reinstall switch box screws.

### Relay Replacement

**1** UNPLUG kiln.

**2** Remove the screws that hold the switch box to the kiln, and let switch box hang by element-to-relay lead wires.

**3** The relay is a switch that sends power to the elements and is controlled by the controller board. Locate the elements that are not firing. The relay that powers them is at the opposite end of the element-to-relay wires. Hold new relay next to the old one aligned in the same direction. Remove wires from old relay, and as they are removed from old relay, install them on the new relay one at a time. (See diagram on pg. 35 if relays differ.)

**4** Unbolt old relay from switch box and replace with new relay.

**5** Check to see that wires are not touching kiln case or the element connectors. **Wires touching element connectors or the kiln case will burn out.** Move switch box into place and reinstall switch box screws.

## GLOSSARY

**BISQUE** Fired, unglazed clay.

**CONE, PYROMETRIC** A small pyramid of ceramic materials that will react to the effect of time, temperature and atmospheric condition inside the kiln in the same way as ceramic ware.

**CRAZING** Hairline cracks in glazed ware. Most common cause is underfired bisque.

**DECAL** A design or picture printed in overglaze or underglaze colors on a protective coating. The decal is slipped from the paper backing onto the appropriate ware and fired for permanency.

**DRY FOOTING** Removing all glaze from the bottom of ware before firing to eliminate the need to stilt.

**ELEMENT** A coil of wire that heats when electricity passes through it.

**ENAMEL** Liquid or powder containing finely ground glass. Usually applied to metal, such as copper, and fired in a kiln.

**GLAZE** A liquid composed of glass particles applied to ceramic ware.

**GREENWARE** Unfired clay objects.

**HEAT SOAK** Maintaining the same temperature inside a kiln.

**HOLD TIME** See "heat soak."

**INFINITE CONTROL SWITCH** A switch that uses a bi-metallic timer to adjust current flow to the heating elements. It makes a clicking noise as the bi-metallic timer cycles on and off. When turned to HIGH, the power flows to the elements continuously.

**INSULATING REFRACTORY FIREBRICK** The type of bricks used to line the interior of your Paragon kiln.

**KILN FURNITURE** The shelves and posts used to position ware inside a kiln.

**KILN SITTER®** A cone activated, mechanical device to shut off the kiln at the proper temperature.

**KILN WASH** A powder mixed with water and brushed on top of shelves and bottom of kiln's firing chamber as protection from drops of fired glaze.

**LIMIT TIMER** A Kiln Sitter with a back-up electrical power shut-off. When a clock on the Kiln Sitter runs out of time, it shuts the kiln off.

**LUSTER** An iridescent overglaze, sometimes metallic.

**MATURING POINT** The stage where clay or glaze has received the correct amount of "heat work." This is usually measured by the 6 o'clock bend of a large pyrometric cone placed on a kiln shelf beside the ware being fired.

**OVERGLAZES** China paints, lusters, gold, etc., usually used over a fired glaze but may also be applied on polished porcelain bisque and fired for permanency.

**PEEPHOLE** The hole in the sidewall of a kiln used to see the interior of the kiln.

**PLASTER** A white powder used for making ceramic molds.

**PORCELAIN** A vitrified, translucent ceramic ware.

**PYROMETER** An instrument for measuring temperature.

**RAMP** Changing the temperature with the TnF controller. If the temperature change is drawn in graph form, the resulting line looks like a ramp.

**RELAY** An electromagnet that, when triggered by current from the TnF controller or other switch, turns on the heating elements.

**SEGMENT** A set of instructions for the TnF controller in the Ramp-Hold mode. A segment changes firing speed, temperature, and can add hold time.

**SILICA** A mineral that will not harden at a very high firing temperature, used for separating porcelain greenware during firing.

**SLIP** A liquid clay used in making ceramic objects by casting.

**STILTS** Small clay or metal-tipped supports used to prevent glazed objects from sticking to the kiln or shelf.

**STONEWARE** A vitreous ceramic body usually made from native clays.

**THERMAL SHOCK** Stress caused by sudden changes in the temperature of ceramic ware. Can cause cracks or breaks.

**THERMOCOUPLE** The measuring unit of a pyrometer that is inserted into the kiln's firing chamber.

**TRANSFORMER** An electrical device in the kiln's switch box that changes the higher voltage from the wall outlet to 24 volts. The lower voltage powers the TnF controller.

**UNDERGLAZE** A decoration applied to greenware or bisque, usually applied under the glaze.

**VENTING** Allowing air to come into the kiln and vapor and gases to escape. This is one of the most important steps in firing.

**VITRIFY** To change into a glassy or a non-porous state by heat and fusion.



**Paragon Industries, Inc.**  
2011 South Town East Blvd.  
Mesquite, Texas 75149-1122  
972-288-7557  
Fax: 972-222-0646